

# Hach Sigma 950 Series Permanent/Portable Open Channel Flow Meters

FLOW

*Hach Sigma 950 Series Permanent/Portable Open Channel Flow Meters provide portable and/or permanent single-channel monitoring plus water quality testing, process control interface, and digital display. Both models offer maximum flexibility for multiple applications—including surcharge or reversed flow conditions, weirs and flumes, and small-to-large channels. Up to three different level sensor technologies and velocity in one meter.*



## Features and Benefits

### Versatility and Customization

For applications that require more than a flow monitor, use the Hach Sigma 950 Open Channel Flow Meter with rainfall, pH, temperature, ORP, dissolved oxygen, and/or conductivity monitoring capability. Three standard level measurement technologies are available—ultrasonic, submerged, or bubbler. The Sigma 950 AV Optiflo flow meter has the additional option of Doppler velocity measurement. All Sigma 950 flow meters also have analog inputs for logging data from other instruments, such as total suspended solids monitors.

### Sampler Pacing and Equipment Control

Use Hach Sigma 950 flow meters to control samplers, pumps, or other equipment based on monitored flow or selected parameter(s) based on high/low set points with built-in relay outputs. Sampler pacing provides the ability to document overflow problems.

### Easy to Use Interface

The large LCD graphics quickly displays information on-site (available in 10 languages) without the inconvenience of paper charts. The built-in keypad makes using laptops in the field optional. A single keystroke can provide an instantaneous data summary and review of all program settings.

### Communications and Data Storage Options

Industry standard SCADA MODBUS ASCII protocol is included in all Sigma 950 flow meters. 4-20 mA outputs are

available for flexible integration with a SCADA system. Remote communications is available via modem or RS-232 connection. Store 18,000 data points in memory (expandable to 116,000 data points).

### Superior Submersible Area Velocity Sensor for Open Channel Applications

The Hach Sigma 950 AV Optiflo flow meter provides Doppler velocity monitoring that uses advanced ultrasonic, one-MHz Doppler technology for flow measurements. This technology avoids signal dropouts and ensures high levels of accuracy in low-flow, full-pipe, or reversed-flow conditions. Installation is fast and single point atmospheric calibration is easy.

### Applications

Hach Sigma 950 Permanent/Portable Open Channel Flow Meter

- Long term or permanent flow studies
- Sanitary sewer evaluation studies
- CSO studies and monitoring
- NPDES stormwater compliance
- Industrial compliance monitoring

Hach Sigma 950 AV Optiflo Permanent/Portable Open Channel Flow Meter

- Applications involving frequent moving of meter to different site conditions

DW = drinking water WW = wastewater municipal PW = pure water / power  
IW = industrial water E = environmental C = collections FB = food and beverage



Be Right™

WW

IW

C

## Specifications\*

### Flow Meter Specifications

#### Units of Measurement

Flow: gps, gpm, gph, lps, lpm, lph, mgd, afd, cfs, cfm, cfh, cfd, m<sup>3</sup>s, m<sup>3</sup>m, m<sup>3</sup>h, m<sup>3</sup>d  
 Totalized Flow: L, m<sup>3</sup>, ft.<sup>3</sup>, gal., acre-ft.

#### Primary Devices

Flumes: Parshall, Palmer Bowlus, Leopold-Lagco, H, HL, HS, trapezoidal  
 Weirs: V-notch (15 to 120°) contracted/non-contracted rectangular, Thelmar, compound Cipolletti  
 Manning Equation: Round, U and rectangular trapezoidal channels  
 Flow Nozzles: Kennison, parabolic, California pipe  
 Head vs. Flow: Custom programmable curve (up to 99 points)

#### Operating Temperature

-10 to 65.5°C (14 to 150°F)

#### Storage Temperature

-40 to 80°C (-40 to 176°F)

#### Time-Based Accuracy

±1 second per day (one level and one velocity, data download once per week, at 10°C (50°F), also affected by site conditions)

#### Totalizers

8-digit resettable and 8-digit non-resettable LCD software totalizer  
 Optional 6-digit non-resettable mechanical totalizer

#### Graphics Display

Back lit LCD  
 Auto-off when not in use  
 SCII Mode: 8 line x 40 character  
 Graphics Mode: 60 x 240 dot  
 Dimensions: 3.8 x 12.7 cm (1.5 x 5 in.)  
 Displays: level vs. time, flow vs. time  
 Optional Displays: rainfall, pH, ORP, temperature, DO, conductivity vs. time, sampler events, and alarm events

#### Keypad

21 position sealed membrane switch with blinking green LED to indicate power on  
 Four "soft keys", functions defined by display

#### Data Storage

Capacity: Up to 512k bytes (402 days of level, velocity, and rainfall readings at 15 minute inter-vals plus 300 events)  
 Monitoring Intervals: 1, 2, 3, 5, 15, 30 or 60-minute intervals

#### Program Memory

Non-volatile programmable flash, can be updated via RS-232 port

#### Sampler Output

12 to 17 Vdc pulse, 100 mA maximum at 500 ms duration

#### Communications

RS-232: up to 19,200 baud  
 SCADA MODBUS communication protocol via RS-232 or optional modem  
 Modem (optional): 14,400 baud  
 Cellular Communications (optional): 14,400 bps, MNP 10-EC Cellular Protocol  
 Pager Alarms

#### Enclosure Material

ABS, UV resistant

#### Enclosure Rating

NEMA 4X,6

#### Power Source

12 Vdc

#### Power Options

6 amp-hr. gel electrolyte rechargeable battery  
 4 amp-hr. Ni-Cad rechargeable battery  
 Lantern battery case with two 6-Volt lantern batteries  
 115 Vac, 230 Vac, or 100 Vac power converter with battery charger

#### Dimensions

34.3 x 25.4 x 24.1 cm (13.5 x 10.0 x 9.5 in.)

#### Weight

6.8 kg (15 lbs.) with batteries

### Sensor Specifications

#### 950 BUBBLER SENSOR

##### Range

0.003 to 3.6 m (0.01 to 11.75 ft.)

##### Accuracy

0.01 to 11.75 ft. ±0.011 ft. (±0.003 m) (linearity and hysteresis at 22°C (72°F))

##### Ambient Operating Temperature

-18 to 63°C (0 to 145°F)

##### Compensated Temperature

0 to 59°C (32 to 138°F)

##### Temperature Error

±0.0003 ft./°F (maximum error within compensated temperature range per degree of change)

##### Air Intakes

Bubble source and reference port desiccant protected.  
 Fittings provided for remote intakes.

#### Filter

10 micron on bubble source intake

#### Line Purge

Bubble line is high pressure purged at programmed intervals, or in manual mode on demand

#### Line Size

0.32 cm (1/8 in.) ID standard

#### 950 ULTRASONIC SENSOR

##### 50 kHz Ultrasonic Transducer

##### Range

38.1 cm to 9.1 m (15 in. to 30 ft.) sensor to liquid

##### Accuracy

1 to 10 ft. ±0.01 ft. (±0.003 m) (at 22°C (72°F), still air, 40 to 70% relative humidity)

#### Span

50 kHz, 0 to 29 ft.

#### Ambient Operating Temperature

-18 to 60°C (0 to 140°F)

#### Temperature Error

±0.000047 ft./°F (maximum error within compensated temperature range per degree of change)

#### Resolution

0.0011 ft.

#### Material

PVC housing  
 Buna-N acoustic window

#### Cable

4-conductor with integral stainless steel support cable  
 Length: 7.6 m (25 ft.) standard

*Continued on next page.*

## Specifications *continued*

### Crystal Specification

50 kHz, 11.5° included beam angle

### Dimensions

9.5 x 7 cm (3.75 x 2.75 in.)

### Weight

0.7 kg (1.5 lbs.)

### 75 kHz Ultrasonic Transducer

#### Range

23 cm to 3.3 m (14 in. to 1 ft.)  
sensor to liquid

#### Accuracy

1 to 10 ft. ±0.01 ft. (±0.003 m)  
(at 22°C (72°F), still air, 40 to 70%  
relative humidity)

#### Span

0 to 15 ft.

#### Ambient Operating Temperature

-18 to 60°C (0 to 140°F)

#### Temperature Error

±0.000047 ft./F° (maximum error within  
compensated temperature range per  
degree of change)

#### Resolution

0.0011 ft.

#### Material

PVC housing  
Buna-N acoustic window

#### Cable

4-conductor with integral stainless steel  
support cable  
Length: 7.6 m (25 ft.) standard

#### Crystal Specification

5° beam angle with horn

#### Dimensions

12.7 x 5.7 cm (5.0 x 2.25 in.)

#### Weight

0.7 kg (1.5 lbs.)

### 75 KHZ ULTRASONIC LEVEL SENSOR (IN-PIPE)

#### Range

0 to 3.35 m (0 to 11 ft.)

#### Accuracy

0.038 to 4.57 m ±0.003 m  
(0.125 to 15 ft. ±0.01 ft.)  
(at 22°C (72°F), still air, 40 to 70%  
relative humidity)

#### Span

0.038 to 4.57 m (0.125 to 15 ft.)

#### Ambient Operating Temperature

-18 to 60°C (0 to 140°F)

#### Temperature Error

±0.00005 m/°C (±0.0001 ft./F°)  
maximum error within compensated  
temperature range per degree of change

#### Resolution

0.019 cm (0.0075 in.)

#### Material

Stainless steel housing  
Buna-N acoustic window

#### Cable

4-conductor  
Length: 7.6 m (25 ft.) standard; 305 m  
(1000 ft.) using RS-485 two wire remote  
sensor option

#### Crystal Specification

75 kHz, 7° included beam angle

#### Dimensions

3.81 x 30 cm (2.0 x 12 in.)

### 950 SUBMERGED PRESSURE SENSOR

#### Range

Choice of:  
2.5 psi: 0.01 to 1.75 m (0.04 to 5.75 ft.)  
5.0 psi: 0.01 to 3.58 m (0.04 to 11.75 ft.)  
10.0 psi: 0.01 to 7.0 m (0.04 to 23 ft.)

#### Accuracy

±0.1% full scale (non-linearity and  
hysteresis)

#### Transducer

Type: Differential piezo resistive with  
balanced bridge  
Orientation: Inverted

#### Maximum Allowable Level

6x over pressure

#### Operating Temperature

0 to 71 °C (32 to 160°F)

#### Compensated Temperature

0 to 36 °C (32 to 96°F)

#### Temperature Error:

2.5 psi: 0.04 to 5.75 ft. ±0.006 ft./F°  
5.0 psi: 0.04 to 11.75 ft. ±0.012 ft./F°  
10.0 psi: 0.04 to 23 ft. ±0.024 ft./F°  
(Maximum error within compensated  
temperature range per degree of  
change)

#### Air Intake

Atmospheric pressure reference is  
desiccant protected

#### Material

316 stainless steel body with titanium  
diaphragm

#### Cable

4-conductor polyurethane sensor  
cable with air vent  
Length: 7.6 m (25 ft.) standard;  
76 m (250 ft.) maximum

#### Dimensions

2.54 x 17.2 cm (1 x 6.75 in.)  
Probe Frontal Area: 0.875 in<sup>2</sup>

#### Weight

0.7 kg (1.5 lbs.)

### SUBMERGED DEPTH/AREA VELOCITY SENSOR

#### Level Measurement

#### Method

Doppler principle/pressure transducer

#### Range

Standard: 0.005 to 3.5 m ±0.007 m  
(0.018 to 11.5 ft. ±0.023 ft.)  
Extended: 0.005 to 10.5 m ± 0.021 m  
(0.018 to 34.6 ft. ±0.07 ft.)  
(Non-linearity and hysteresis)

#### Maximum Allowable Level

3x over pressure

#### Operating Temperature

0 to 71°C (32 to 160°F)

#### Compensated Temperature

0 to 30°C (32 to 86°F)

#### Temperature Error

0.005 to 3.5 m ±0.0022 m/°C  
(0.018 to 11.5 ft. ±0.004 ft./°F)  
0.018 to 10.5 m ±0.006 m/°C  
(0.018 to 34.6 ft. ±0.012 ft./°F)  
(Maximum error within compensated  
temperature range per degree of  
change)

#### Velocity Induced Error on Depth (patent pending)

0 to 3.05 m/s (0 to 10 ft./sec.) = 0.085%  
of reading

#### Air Intake

Atmospheric pressure reference is  
desiccant protected

*Continued on next page.*

## Specifications *continued*

### Velocity Measurement

#### **Method**

Doppler ultrasonic

#### **Transducer Type**

Twin 1 MHz piezoelectric crystals

#### **Range**

-1.52 to 6.10 m/s (-5 to 20 fps)

#### **Zero Stability**

< 0.015 m/s (0.05 fps)

#### **Accuracy**

±2% of reading

#### **Depth for Velocity**

2 cm (0.8 in.) minimum, typical

#### **Operating Temperature**

-18 to 60°C (0 to 140°F)

#### **General**

#### **Material**

Polymer body with stainless steel diaphragm

#### **Cable**

Urethane sensor cable with air vent

*Length:* 7.6 m (25 ft.) standard;

76 m (250 ft.) maximum

#### **Dimensions**

2 x 3.8 x 12.7 cm (0.8 x 1.5 x 5 in.)

### BUBBLER LEVEL/AREA

### VELOCITY SENSOR

#### **Level Measurement**

#### **Method**

Doppler principle/pressure transducer

#### **Range**

0.003 to 3.6 m (0.01 to 11.75 ft.)

#### **Accuracy**

0.01 to 11.75 ft. ±0.011 ft. (0.033 m)  
(linearity and hysteresis at 22°C (72°F))

#### **Ambient Operating Temperature**

-18 to 63°C (0 to 145°F)

#### **Compensated Temperature**

0 to 59°C (32 to 136°F)

#### **Temperature Error**

±0.0003 ft./°F (maximum error within compensated temperature range per degree of change)

#### **Air Intakes**

Bubble source and reference port desiccant protected.  
Fittings provided for remote intakes.

#### **Filters**

10 micron on bubble source intake

#### **Line Purge**

Bubble line is high pressure purged at programmed intervals, or in manual mode on demand

### Velocity Measurement

#### **Method**

Doppler ultrasonic

#### **Transducer Type**

Twin 1 MHz piezoelectric crystals

#### **Range**

-1.52 to 6.10 m/s (-5 to 20 fps)

#### **Zero Stability**

< 0.015 m/s (0.05 fps)

#### **Accuracy**

±2% of reading

#### **Depth for Velocity**

2 cm (0.8 in.) minimum, typical

#### **Operating Temperature**

-18 to 60°C (0 to 140°F)

#### **Dimensions**

1.12 x 3.81 x 6.86 cm

(0.44 x 1.5 x 2.7 in.)

### VELOCITY SENSOR

#### **Method**

Doppler principle

#### **Accuracy**

±2% of reading

#### **Zero Stability**

±1.52 cm (±0.05 fps)

#### **Nose Angle**

20° from horizontal

#### **Cable**

*Length:* 7.6 m (25 ft.) standard;

custom cable lengths to 76 m (250 ft.)

*Diameter:* 0.57 cm (0.225 in.)

#### **Materials**

*Sensor:* Polymer

*Cable:* Urethane

*Mounting Hardware:* Stainless steel

#### **Dimensions**

1.5 x 3.8 x 9.7 cm (0.5 x 1.5 x 3.7 in.)

## Factory Installed Options

### pH-TEMPERATURE/ORP METER

#### **Control/Logging**

Field selectable to log pH-temperature or ORP independent of flow or in conjunction with flow; also controls sample collection in response to value exceeding low/high set points

#### **pH/Temperature Sensor**

Temperature compensated; impact resistant ABS plastic body; combination electrode with porous Teflon® junction

#### **Range**

2 to 12 pH within specifications;  
0 to 14 pH maximum range

#### **Operating Temperature**

-18 to 80°C (0 to 176°F)

#### **Recording Intervals**

1, 2, 3, 5, 6, 10, 12, 15, 30,  
and 60 minutes

#### **Probe Pre-Amplifier/Junction Box**

NEMA 4X with labeled terminal strip

#### **Dimensions**

1.9 x 15.2 cm (0.75 x 6 in.) with  
1.9-cm (0.75-in.) MPT cable end

### INTEGRAL DISSOLVED OXYGEN/TEMPERATURE METER

#### **Control/Logging**

Field selectable to log dissolved oxygen independent of flow or in conjunction with flow; also controls sample collection in response to value exceeding low/high set points

#### **Measurement Method**

Polargraphic

#### **Sensor**

Temperature compensated; impact resistant polypropylene body

*Continued on next page.*

## Specifications *continued*

### Range

0 to 20 mg/L dissolved oxygen

### Resolution

0.01 mg/L

### Accuracy

±0.2 mg/L

### Operating Temperature

0 to 50°C (32 to 122°F)

### Recording Intervals

1, 2, 3, 5, 6, 10, 12, 15, 20, 30, and 60 minutes

### Dimensions

1.65 x 12.7 cm (0.65 x 5 in.) with 1.9-cm (0.75-in.) MPT cable end

### INTEGRAL CONDUCTIVITY/TEMPERATURE METER

#### Control/Logging

Field selectable to log conductivity independent of flow or in conjunction with flow, also controls sample collection in response to value exceeding low/high set points

#### Sensor

Temperature compensated; impact resistant polypropylene body

### Range

0 to 20 mS/cm

### Resolution

0.01 mS/cm or 0.01 µS/cm (user selectable)

### Accuracy

±1% of reading +0.05 mS/cm

### Operating Temperature

0 to 50°C (32 to 122°F)

### Recording Intervals

1, 2, 3, 5, 6, 10, 12, 15, 20, 30, and 60 minutes

### Dimensions

1.70 x 12.7 cm (0.67 x 5 in.) with 1.9-cm (0.75-in.) MPT cable end

### RAIN GAUGE INPUT

For use with Hach Tipping Bucket Rain Gauge.  
Flow Meter records rainfall data in 0.01-in. increments.  
Flow measurement can be initiated based upon field selectable rate of rain.

### ANALOG INPUT DATA-LOGGING CHANNELS

Up to seven additional data-logging channels record data from external sources.  
Field assignable channel name(s) and units.  
-4 to +4 Vdc; ±0.5% full scale voltage accuracy  
0 to 20 mA; ±0.2% full scale 4-20 mA accuracy with 200 ohm impedance

### 4 TO 20 MA OUTPUTS

Up to two integral field assignable outputs  
Optically isolated  
Up to 600 ohm load per output  
0.1 % FS error

### ALARM RELAYS

Up to four integral alarm relays  
10 amp, Form C  
User assignable to any internal or external data channel

### MECHANICAL TOTALIZER

6-digit non-resettable mechanical totalizer  
*Selectable units:* gal., liters, ft.<sup>3</sup>, m<sup>3</sup>, acre-ft.

### MODEM

14,400 baud rate  
CRC auto to check sum  
FCC approved  
Cellular compatible

### EXPANDED MEMORY

Increase memory from 18,432 data points to 116,736 data points

### AC POWER BACKUP

Provides power in the event of an AC power failure  
Internal trickle charger maintains 6 amp-hour battery

*Teflon® is a registered trademark of E.I. DuPont de Nemours Inc.*

*\*Specifications subject to change without notice.*

## Engineering Specifications

### Flow Meter

1. The flow meter shall operate on 12 Vdc, which is supplied by a battery or 115 Vac power converters.
2. All electrical components shall be enclosed in a NEMA 4X-6 enclosure. The enclosure shall have a continuous hinged front cover to protect the display and keypad and shall maintain NEMA 4X,6 with the cover open.
3. The enclosure shall contain desiccant and a front panel humidity indicator.
4. Current data shall be displayed on the flow meter front panel by means of an external push button on the enclosure. The meter shall not require opening of a cover to see current status.
5. The meter shall have an 8 line x 40-character backlit liquid crystal graphics display. In addition to indicating all programming steps and current status such as level, velocity and flow rate, the display shall show all logged data in field selectable tabular and graphics (x-y plot) formats.
6. All program entries shall be entered via a sealed front panel keypad, and indicated on the front panel display. The keypad and display shall meet NEMA 4X-6 standards.
7. A personal computer or any other external means shall not be required to program the flow meter or integral logger or access data.
8. Flow meter programming/measurements:
  - a. The flow meters shall be field programmable for primary devices including:
    - i. Weirs: V-notch weirs (any angle from 22.5 to 120 degrees, compound V-notch/rectangular weirs, contracted and non-contracted rectangular weirs, trapezoidal weirs, and Thel-Mar weirs.
    - ii. Flumes: Parshall (1 to 144 inch), Palmer Bowlus (4 to 72 inch), trapezoidal (60 degree small, large, and extra large, 45 degree 2 and 12 inch), H. HL, and HS type flumes, and Leopold-Lagco (4 to 72 inch).
    - iii. Nozzle: California pipe method; Manning equation for round, U-channel, rectangular, and trapezoidal cross sections; power curve equation.
    - iv. Head vs. flow tables: Two tables of up to 99 (head, flow) points per table (tables may be stored in flow meter's memory and retrieved as required).
  - b. Field selectable units of measurement shall include:
    - i. Level: Inches, feet, centimeters, and meters.
    - ii. Flow rate: GPS, GPM, GPH, MGD, AFD, LPS, LPM, LPH, CFS, CFM, CFH, CFD, CMS, CMM, CMH, CMD.
    - iii. Total flow: Gallons, cubic feet, acre-feet, liters, and cubic meters.
9. Flow totalizing:
  - a. The flow meter shall have two software totalizers, one resettable and the other resettable.
  - b. (Optional) The meter shall include a 6-digit non-resettable electro-mechanical totalizer, protected to meet NEMA 4X, 6 standards.
10. Sampler pacing:
  - a. The flow meter shall have a 12 Vdc pulse output for pacing an automatic liquid sampler in proportion to flow, with field selectable flow volume between pulses.
  - b. The meter shall be capable of initiating a sampler on level, flow rate, and flow rate of change.
11. Integral metering devices (optional):
  - a. The meter shall be equipped with an integral pH-temperature/ORP meter. The pH meter shall have a range of 0 to 14 pH with a  $\pm 1\%$  resolution over an operating range of 0 to 176 degrees F.
  - b. The meter shall be equipped with an integral temperature meter. The temperature meter shall have an operating range of 0 to 176 degrees F. The meter shall include a platinum RTD probe in a stainless steel body with 25-foot cable.
  - c. The meter shall be equipped with an integral dissolved oxygen (DO) meter. The DO meter shall have a range of 0 to 20 mg/L (DO) with 0.01 mg/L resolution and 3% (1 ppm) accuracy.
  - d. The meter shall be equipped with an integral conductivity meter. The conductivity meter shall have a range of 0 to 20 mS/cm with 0.01 mS/cm resolution and 2% (0.01ms) of reading accuracy.
  - e. The meter shall be equipped with a rain gauge input. The sampler shall accept contact closure inputs from an external rain gauge.
  - f. The meter shall be equipped with seven external analog inputs. The first four channels shall be capable of logging a 4-20 mA current input, and the remaining three channels shall be set up to log -4.5 to +4.5 Vdc voltage input.
12. The flow meter and sensor shall be the Sigma Model 950 Permanent/Portable Open Channel Flow Meter OR Sigma Model 950 AV Optiflo Permanent/Portable Open Channel Flow Meter manufactured by Hach Company.

## Dimensions

Placement of Hach Sigma 950 Series Permanent/Portable Open Channel Flow Meters depends on the suitability of the monitoring site. Select sites that have normalized flow and minimal turbulence. Turbulence can make it difficult to detect an average velocity in the flow stream. Obstructions, vertical drops, pipe bends, and elbows can create turbulence and affect the accuracy of measurements. Mounting options for Sigma 950 flow meters include wall mounting, suspension harness installation, or manhole rung hanger.

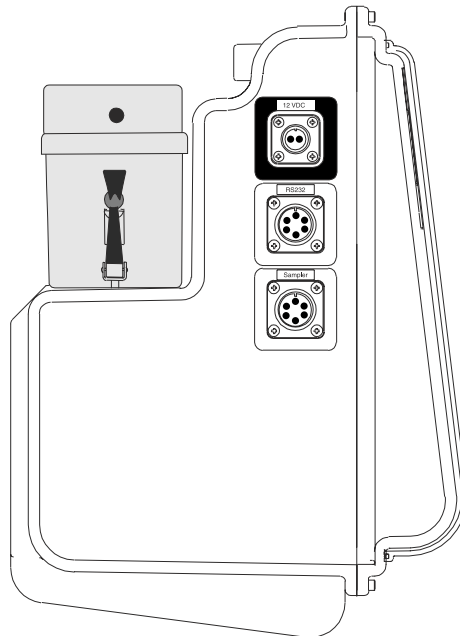
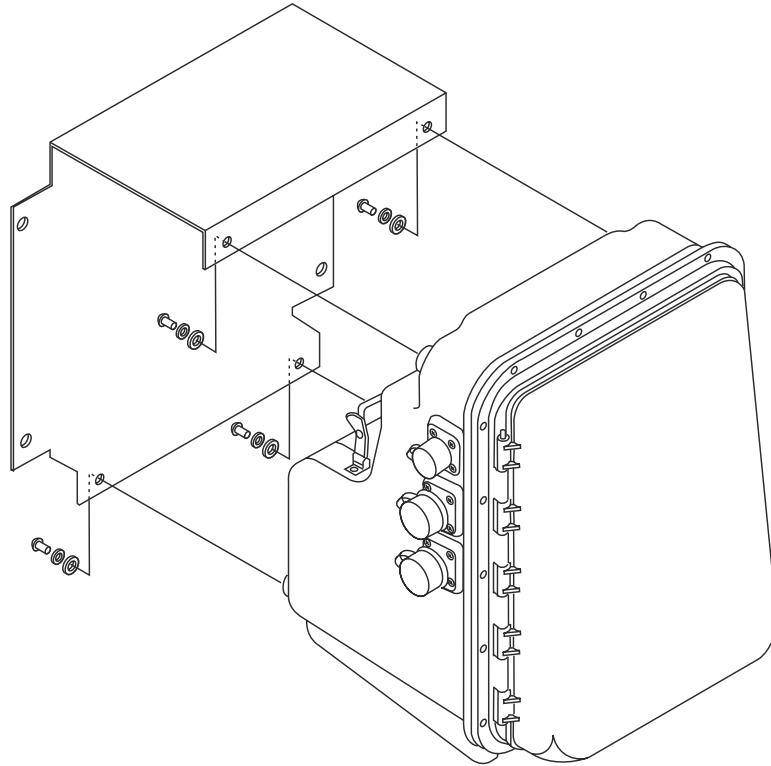

## Ordering Information

### Flow Meter Bundles

<b>36729-50</b>	950 Bubbler Flow Meter; includes 25 ft. tubing	<b>2691</b>	First Set Two (2) Alarm Relays with settable trip points
<b>36809-50</b>	950 Submerged Pressure Flow Meter; includes 25 ft. sensor cable	<b>2707</b>	Second Set Two (2) Alarm Relays with settable trip points
<b>32869-51</b>	950 75 kHz Down-look Ultrasonic Flow Meter; includes 25 ft. sensor cable	<b>4578</b>	Modem; 14,400 baud (domestic lines only)
<b>32869-52</b>	950 75 kHz In-Pipe Ultrasonic Flow Meter; includes 25 ft. sensor cable	<b>Sensor Mounting Hardware</b>	
<b>32489-50</b>	950 Bubbler AV Flow Meter; includes 25 ft. of sensor cable	<b>1361</b>	Spring Ring for 6-in. diameter pipe
<b>35229-50</b>	950 Submerged AV Flow Meter; includes 25 ft. of sensor cable	<b>1362</b>	Spring Ring for 8-in. diameter pipe
<b>39599-52</b>	950 75k Hz Ultrasonic AV Flow Meter with In Pipe Ultrasonic and Velocity Sensors	<b>1363</b>	Spring Ring for 10-in. diameter pipe
		<b>1364</b>	Spring Ring for 12-in. diameter pipe
		<b>3263</b>	Sensor Mounting Clip; for 88000, wafer velocity, and bubbler level velocity sensors
		<b>3868</b>	Portable Bracket; for in-pipe ultrasonic sensor mounting clip
		<b>3875</b>	Permanent In-Pipe Ultrasonic Sensor Mounting Bracket
		<b>3305</b>	Velocity Sensor Mounting Plate
		<b>9574</b>	Insertion Tool; for non-confined space entry
		<b>2974</b>	Permanent Wall Mount Bracket; for down-looking ultrasonic sensor
		<b>2904</b>	Floor or Wall Adjustable Mounting Bracket; for down-looking ultrasonic sensor
		<b>9538</b>	Tripod Mounting Bracket; for down-looking ultrasonic sensor
		<b>2883</b>	Cable Straightener; for down-looking ultrasonic sensor
		<b>3183</b>	Cable Grip; for down-looking ultrasonic sensor

### Integral Water Quality Options and Sensors

<b>2684</b>	Factory Installed Integral pH-Temp/ORP Sensor; includes pre-amp interface
<b>3328</b>	pH-Temperature Sensor (grounded); includes 25 ft. cable
<b>2080</b>	ORP Sensor; includes 25 ft. cable
<b>3226</b>	Factory installed DO and Conductivity Sensor; includes pre-amp interface
<b>3228</b>	Factory installed DO and EC Option with three 4-20mA Input Data Logging, includes pre-amp interface
<b>3216</b>	DO Probe Kit; includes 25 ft. cable.
<b>3225</b>	Conductivity Probe Kit; includes 25 ft. cable
<b>3222</b>	DO Probe only; includes 25 ft. cable
<b>3223</b>	Conductivity Probe only; includes 25 ft. cable

### Communication and Control Interfaces

<b>2676</b>	First 4-20 mA Output; includes 25 ft. cable
<b>2923</b>	Second 4-20 mA Output

### Cables and Interfaces

<b>1727</b>	Sampler or Flow Meter to PC Cable
<b>3358</b>	RS232 Extension Cable

### Accessories

<b>77247-00</b>	Silicon Oil; dual 50-ml pack (refills 100 sensors)
<b>77248-00</b>	Silicon Oil Refill Kit; includes dispensing tool and oil packs
<b>77256-00</b>	Oil-Filled Sub-AV Sensor Kit
<b>77300-00</b>	Retrofit Kit (converts non oil-filled to oil-filled); includes Silicon Oil Refill Kit

*At Hach, it's about learning from our customers and providing the right answers. It's more than ensuring the quality of water—it's about ensuring the quality of life. When it comes to the things that touch our lives...*

*Keep it pure.*

*Make it simple.*

*Be right.*

*For current price information, technical support, and ordering assistance, contact the Hach office or distributor serving your area.*

*In the United States, contact:*

HACH COMPANY World Headquarters  
P.O. Box 389  
Loveland, Colorado 80539-0389  
U.S.A.  
Telephone: 800-227-4224  
Fax: 970-669-2932  
E-mail: orders@hach.com  
**www.hach.com**

*U.S. exporters and customers in Canada, Latin America, sub-Saharan Africa, Asia, and Australia/New Zealand, contact:*

HACH COMPANY World Headquarters  
P.O. Box 389  
Loveland, Colorado 80539-0389  
U.S.A.  
Telephone: 970-669-3050  
Fax: 970-461-3939  
E-mail: intl@hach.com  
**www.hach.com**

*In Europe, the Middle East, and Mediterranean Africa, contact:*

HACH LANGE GmbH  
Willstätterstraße 11  
D-40549 Düsseldorf  
GERMANY  
Tel: +49 (0) 211 5288-0  
Fax: +49 (0) 211 5288-143  
E-mail: info@hach-lange.de  
**www.hach-lange.com**

Lit. No. 2547

F63 Printed in U.S.A.

©Hach Company, 2006. All rights reserved.

*In the interest of improving and updating its equipment, Hach Company reserves the right to alter specifications to equipment at any time.*



**Be Right™**