

ENMET Corporation
PO Box 979
Ann Arbor, MI 48106-0979

TARGET Series
Portable Gas Detector
Operation & Maintenance Manual

80012-014
July 1999
Updated September 1999
MCN-225; 12/16/99
MCN-235; 07/12/00
MCN-245; 09/26/00
MCN-250; 03/20/01
MCN-263; 08/22/01
MCN-275, 05/01/02

Table of Contents

1.0 Introduction	1
1.1 Warnings and Cautions.....	1
1.2 Unpack.....	1
1.3 Check Order.....	2
1.4 Serial Numbers.....	2
2.0 TARGET Features	2
2.1 Sensors.....	2
2.2 Other features include:.....	2
2.4 Locations and Data logging.....	4
3.0 Instrument Operation	4
3.1 Turning the Instrument On and Off.....	4
3.1.1 Turning the <i>TARGET</i> On.....	4
3.1.2 Turning the <i>TARGET</i> Off.....	4
3.2 Charging the Battery.....	5
3.3 Display Backlight.....	6
3.4 Alarms.....	6
3.4.1 Instantaneous Gas Alarm.....	6
3.4.2 STEL/TWA Alarms.....	6
3.4.3 Over-range and Under-range Alarms.....	7
3.4.4 Low Battery.....	7
3.4.5 Fault.....	7
3.5 Pop-Up Menu.....	7
3.5.1 Auto-Zero.....	7
3.5.2 Calibration Status.....	8
3.5.3 Combustible Gas Display.....	8
3.5.4 Locations.....	8
3.5.5 Internal Sampling Pump.....	9
4.0 Basic User Operation	10
4.1 Date/Time/Battery Information.....	10
4.2 Alarms Values.....	10
5.0 Advanced User Operation	11
5.1 Date/Time/Battery Information.....	11
5.2 Alarms Values.....	11
5.3 Min/Max Values.....	11
5.4 TWA Values.....	11
5.5 STEL Values.....	12
6.0 Maintenance Operations	12
6.1 Recommendations.....	12
6.2 Standard Maintenance Menu.....	12
6.3 Calibration.....	13
6.3.1 Calibration Menu.....	13
6.3.2 Zero Adjust.....	13
6.3.3 Applying Span Gas.....	13
6.4 Advanced Maintenance Menu.....	15
6.4.1 Calibration.....	15
6.4.2 Setting Instantaneous Alarms.....	16
6.4.3 Enable Sensors.....	16
6.4.4 Set Clock/Chirp.....	16
6.4.5 Set Password.....	16

6.4.6 Set Battery Type	17
6.4.7 Set Operation Menu	17
6.4.8 Internal Pump Calibration.....	17
6.5 Replacing Battery Pack.....	18
6.6 Replacing Internal Pump	18
6.7 Replacing Sensors	19
7.0 Instrument Information.....	20
7.1 Replacement Parts List.....	20
7.2 Target Specifications.....	21
8.0 Default Alarm and Configurations.....	22
9.0 Flow Diagrams.....	23
9.1 Basic Operation Menu	23
9.2 Standard Maintenance Menu.....	24
9.3 Advanced Operation Menu.....	25
9.4 Advanced Maintenance Menu.....	26
10.0 Troubleshooting.....	27
11.0 WARRANTY.....	28

List of Illustrations

FIGURE 1: FRONT VIEW.....	3
FIGURE 2: SENSOR VIEW.....	3
FIGURE 3: TOP VIEW	3
FIGURE 4: BOTTOM VIEW	3
FIGURE 5: MAIN GAS DISPLAY	3
FIGURE 6: INSERT CHARGE JACK.....	5
FIGURE 7: REMOVE CHARGE JACK.....	5
TABLE 1: BATTERY LIFE.....	6
TABLE 2: PROGRAMMED FLAMMABLE GAS COEFFICIENTS.....	8
FIGURE 8: CALIBRATION ADAPTER ATTACHMENT	14
FIGURE 9: REPLACING BATTERY PACK AND INTERNAL PUMP	18
FIGURE 9A: REPLACING INTERNAL PUMP FOR INSTRUMENTS WITH S/N 0699 AND BELOW	18
FIGURE 10: REMOVE SHORTING CLIP	19
FIGURE 11: REPLACING SENSORS.....	19
TABLE 3: DEFAULT ALARM.....	22
TABLE 4: DEFAULT CONFIGURATION	22
TABLE 5: TARGET MENU QUICK REFERENCE	23

Reference Information:

NOTE: [important information about use of the instrument.]

CAUTION: [affects equipment – if not followed may cause damage to instrument, sensor etc...]

WARNING: [affects personnel safety – if not followed may cause bodily injury or death.]

1.0 Introduction

1.1 Warnings and Cautions

The **TARGET Series** gas detectors are designed to detect hazardous atmospheric conditions. An indication of life threatening hazards should be taken very seriously. **NEVER ignore an alarm condition.**

WARNINGS:

- Any rapid upscale combustible gas reading followed by a declining or erratic reading may indicate a gas concentration beyond the upper-scale limit. This may indicate a flammable concentration.
- Off-scale readings may indicate a flammable concentration.
- Electromagnetic interference (EMI) signals may cause incorrect operation.
- **CSA requirement:** Before each day's usage, instrument sensitivity must be tested on a known concentration of methane between 25-50% LEL. Accuracy must be within -0 to +20% of the actual concentration applied. Accuracy may be corrected, if necessary, by performing sensor calibration.
- Oxygen deficient conditions can cause lower combustible gas readings than actual concentrations.
- Oxygen enriched conditions can cause higher combustible gas readings than actual concentrations.
- The instrument batteries should only be charged in a non-hazardous location.
- The instrument should only be connected to a computer in a non-hazardous location.

CAUTIONS:

- In case of an atmospheric alarm condition, follow your organization's established procedures for such a situation. Evacuating the affected area is usually the first course of action, followed by ventilation and re-testing of the environment prior to re-entry.
- Silicone compound vapors may adversely affect the **TARGET** instrument's standard combustible sensor causing lower readings than actual concentrations. If the instrument has been exposed to silicone vapors it is strongly recommended that the instrument be recalibrated prior to its next use. Repeated exposure to silicone compounds will prematurely destroy the standard combustible sensor.

NOTE: The optional MOS combustible sensor is much less susceptible to silicone poisoning, but instrument calibration should take place on a more frequent schedule.

- The sensor sampling area must be kept clean. Contamination of this area can prevent proper operation of the sensors.

Any sensor that fails calibration procedures should be replaced and recalibrated immediately.

The combustible portion of this instrument has been assessed by CSA for performance. Users may refer to ANSI/ISA RP12.13 or an equivalent international recommended practice for guidance in the use of combustible gas detection equipment.

TARGET instruments with a CSA logo on the serial number label are approved for Intrinsic Safety when used in Class 1, Division 1, Group A, B, C, D Hazardous Location environments.

NOTE: Any specifications stated in this manual may change without notice.

1.2 Unpack

Unpack the **TARGET Series** instrument and examine it for shipping damage. If such damage is observed, notify both **ENMET** customer service personnel and the commercial carrier involved immediately.

Regarding Damaged Shipments

NOTE: It is your responsibility to follow these instructions. If they are not followed, the carrier will not honor any claims for damage.

- This shipment was carefully inspected, verified and properly packaged at our company and delivered to the carrier in good condition.
- When it was picked up by the carrier at **ENMET**, it legally became your company's property.
- If your shipment arrives damaged:
 - Keep the items, packing material, and carton "As Is." Within 5 days of receipt, notify the carrier's local office and request immediate inspection of the carton and the contents.
 - After the inspection and after you have received written acknowledgment of the damage from the carrier, contact **ENMET** Customer Service for return authorization and further instructions. Have your Purchase Order and Sales Order numbers available.

- ❑ **ENMET** either repairs or replaces damaged equipment and invoices the carrier to the extent of the liability coverage, usually \$100.00. Repair or replacement charges above that value are your company's responsibility.
- ❑ The shipping company may offer optional insurance coverage. **ENMET** only insures shipments with the shipping company when asked to do so in writing by our customer. If you need your shipments insured, please forward a written request to **ENMET** Customer Service.

Regarding Shortages

If there are any shortages or questions regarding this shipment, please notify **ENMET** Customer Service within 5 days of receipt at the following address:

ENMET Corporation
680 Fairfield Court
Ann Arbor, MI 48108
734-761-1270 734-761-3220 Fax

1.3 Check Order

Check, the contents of the shipment against the purchase order. Verify that the **TARGET Series** instrument is received as ordered. Follow the procedure outlined in paragraph 2.0 to determine your instrument configuration. If there are accessories on the order, ascertain that they are present. Check the contents of calibration kits. Notify **ENMET** customer service personnel of any discrepancy immediately.

1.4 Serial Numbers

Each **TARGET Series** instrument is serialized. These numbers are on tags on the equipment and are on record in an **ENMET** database.

2.0 TARGET Features

2.1 Sensors

The **TARGET Series** by **ENMET** Corporation is a multi-gas portable instrument that may be configured with one to six sensors. Sensors include:

- Oxygen
- Flammable
- Broad Range Hydrocarbon Toxic MOS (Metallic Oxide Semiconductor) Sensor
- Carbon monoxide
- Hydrogen sulfide
- Ammonia, Sulfur dioxide, Chlorine and many more will be available soon.

2.2 Other features include:

- Metal enclosure for improved durability
- RFI resistant design
- Four line display with backlight
- Push-button calibration procedure
- Programmable combustible sensor
- Optional internal sampling pump
- Audible alarms
- Visual alarm for each sensor
- Dual alarm levels for Toxic and Combustible gases
- Oxygen deficiency and enrichment alarms
- Maximum and Minimum tracking of gas readings
- Peak hold
- Latching alarms
- STEL and TWA alarms
- Datalogging
- Calibration reminder
- Intrinsically safe by design. CSA approved.
- CE approval pending

See Figures 1 and 2

Visual Alarms	There are visual alarms for each of the gas sensors installed.
Display	4 line by 20 character dot-matrix LCD with on-demand back light.
I/O and Charging Port	Connector for battery charger, computer cable, remote annunciator cable, and earphone.

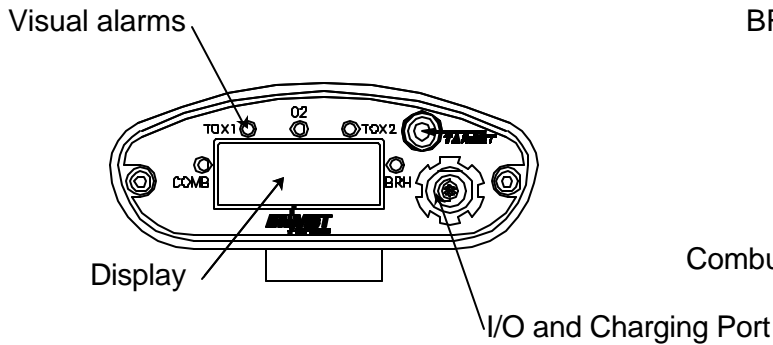

Figure 1: Front View

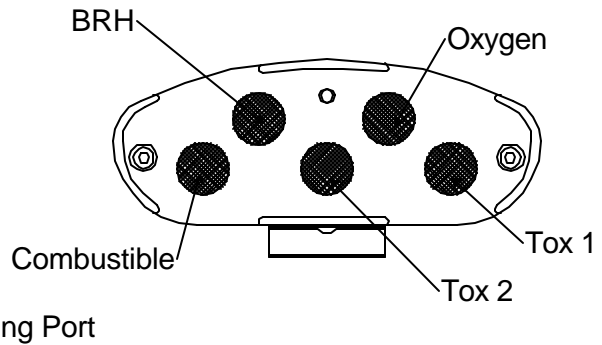

Figure 2: Sensor View

See Figures 3 and 4

Horn	Audio Alarm
ON/OFF Button	Power button and back light
SELECT Button	SELECT button and audio defeat
MENU Button	MENU button
Gasket	For sealing instrument enclosure

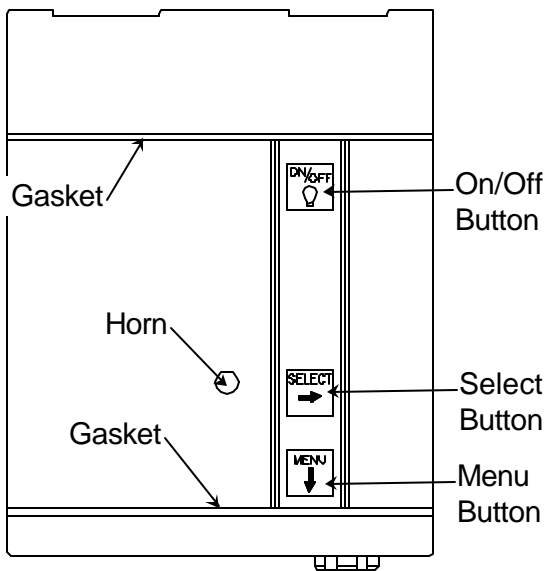

Figure 3: Top View

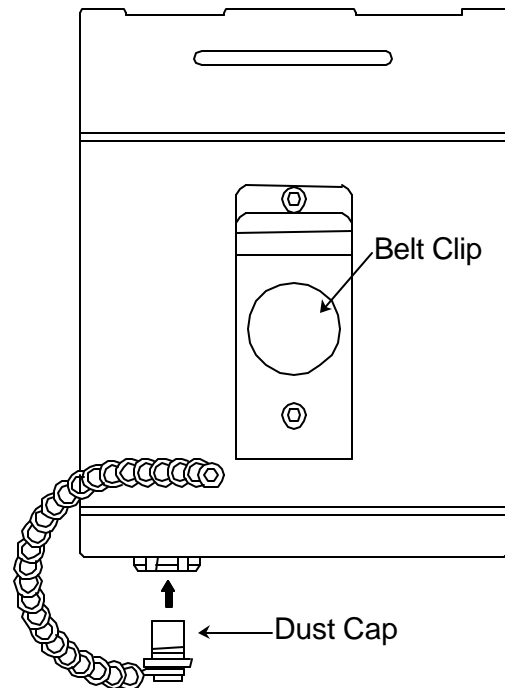

Figure 4: Bottom View

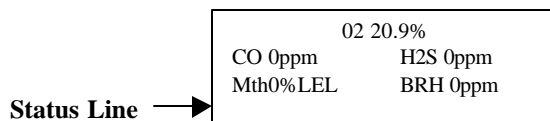

Figure 5: Main Gas Display

2.4 Locations and Data logging

The **TARGET** instrument has the ability to store users or location information and log exposure information. **TARGET** Trakker software is required for these operations. Further details on its operation and interaction with the instrument is provided in software manual. If desired, contact ENMET or your local distributor.

3.0 Instrument Operation

3.1 Turning the Instrument On and Off

3.1.1 Turning the **TARGET** On

Press and hold the **ON/OFF** button. The audio alarm may squeal slightly while holding the **ON/OFF** button. This is normal. When the instrument turns on, it beeps once and all of the alarm LEDs light up. The **TARGET** performs a one minute warm-up procedure which includes a self test, checking sensor signals and instrument electronics. At the end of the one minute warm-up procedure, the instrument will beep several times before giving the user the option to perform an auto zero function, or other functions that appear in the Pop-Up menu. See section 3.5 for further information.

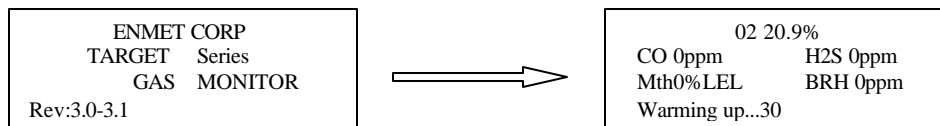

Example: Warm-up Displays

3.1.2 Turning the **TARGET** Off

Press and hold the **ON/OFF** button for approximately three seconds. The instrument shows a three second count down and beeps just before shutting down. To protect the user from accidental shut down, the **ON/OFF** button must be held for the duration of the three second count down. The audio alarm beeps once to indicate instrument shut down.

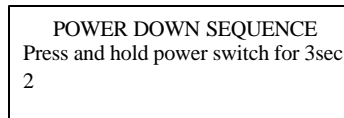

Example: Power Down Display

3.2 Charging the Battery

WARNING: Never charge the **TARGET** instrument in a hazardous location

The **TARGET** instrument has a 4.8 volt, nickel metal hydride (NiMH) battery pack. The supplied battery charger charges the instrument batteries usually in three to four hours. The charger is supplied with a power cord for connection to 110 VAC wall outlet. The batteries may also be charged in the same time frame with a 12 VDC vehicle accessory adapter. Instrument electronics protect alkaline battery packs from being charged by the **TARGET** battery charger.

NOTE: The connector is keyed and will only go in one way.

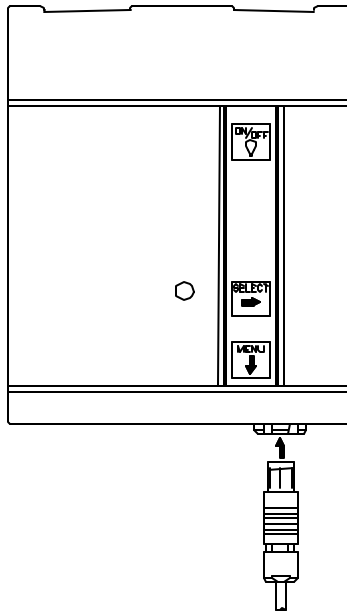

Figure 6: Insert Charge Jack

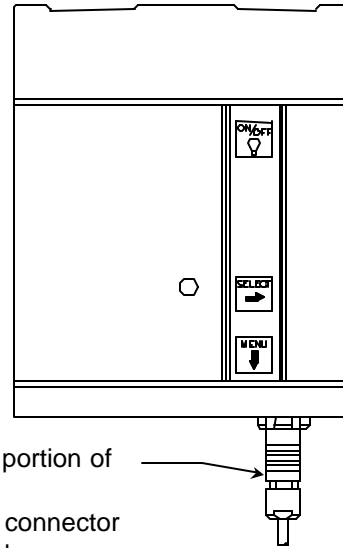

Figure 7: Remove Charge Jack

- Plug the battery charger into the wall and then plug the charger connector in to the **I/O and charging port** on the front of the **TARGET** instrument. See figures 6 and 7.
- Once inserted, the instrument's display activates and shows the charge status:

- When the batteries are fully charged, the following is displayed providing information on charge time, capacity and status:

```

    BATTERIES CHARGING
    Charge started:
    May 15 1999 5:29:00 pm
    Chrg:25% Time: 0:01
    
```

Example: Display, Battery Charging

```

    CHARGING DONE
    Charge started:
    May 15 1999 5:29:00 pm
    Chrg:100% Time: 3:15
    
```

Example: Display, Charging Complete

NOTE: While charging the batteries, the instrument enclosure becomes warm to the touch. The instrument electronics detect peak battery charge and stop charging at the appropriate time. Once charging is complete, the enclosure will cool to room temperature.

The instrument may be left indefinitely on the charger. It is recommended to do so, to keep the battery pack at full charge.

CAUTION: When removing the charge jack be sure to grab onto **only the ribbed portion** of the connector, otherwise the connector will not release. See Figure 7.

Table 1: Battery Life

Normal operation with standard sensors	A fully charged NiMH battery pack may provide up to 18 hours of operation. It may take several charge and discharge cycles to achieve optimal battery performance.
Normal operation with BRH toxic sensor installed Or while using the optional internal pump.	If the BRH toxic gas sensor is installed or the internal motorized sample pump is used continuously, instrument operation time is reduced. Typical operation time with the BRH sensor or the activated internal pump is 11 hours.
Normal operation with the BRH sensor and optional internal pump.	Operation time with both the BRH sensor and pump activated is approximately 8 hours.

3.3 Display Backlight

The **TARGET** display backlight automatically activates during an alarm condition. To manually activate the backlight, quickly press and release the **ON/OFF** button. The backlight remains on for approximately 30 seconds.

3.4 Alarms

Never ignore an alarm condition! In case of an alarm condition, follow your organization’s established procedures for such a situation. If the cause of the alarm is an atmospheric condition, evacuating the affected area is usually the first course of action, followed by ventilation and re-testing of the environment prior to re-entry.

If an alarm for any sensor is acknowledged (silenced), the audio alarm reactivates in case of an additional alarm condition for that sensor or any others occur.

3.4.1 Instantaneous Gas Alarm

The **TARGET** Series instrument has two levels of instantaneous alarm for each installed sensor. For the oxygen channel, the alarms are for oxygen deficiency and enrichment. For the toxic and combustible sensors, there are low and high alarms. Default alarm values are shown in Section 9. Values in the instrument may be viewed by entering the Operational Menu. See Section 4.2 or 5.2. All instantaneous alarms are latching and continue to activate audio and visual indicators until they are acknowledged by pressing the **SELECT** button. If an alarm is acknowledged, visual indication continues until the condition clears.

The low level alarm for toxic and combustible gases is identified by a flashing LED and a pulsed audio tone. The audio alarm may be acknowledged and silenced by pressing the **SELECT** button. If the alarm condition doesn’t clear, the audio alarm will reactivate in 10 minutes.

The high level alarms for toxic and combustible gases is identified by a steady LED and a continuous audio tone. The oxygen alarms act in this same manner. The audio alarm may be acknowledged and silenced by pressing the **SELECT** button. If the alarm condition doesn’t clear, the audio alarm will reactivate in 5 minutes.

During either instantaneous alarm condition, the display automatically peak holds the highest concentration of the affected sensor until the alarm is acknowledged. If a low level “pulsed” alarm occurs, and is acknowledged, the audio alarm reactivates as a steady tone if the high level alarm level is exceeded.

3.4.2 STEL/TWA Alarms

The STEL and TWA alarms are present for the TOX1 and TOX2 sensors. Default alarm values are shown in Section 9. Values in the instrument may be viewed by entering the Operational Menu. See Section 4.2 or 5.2.

A STEL or TWA alarm is identified by a steady LED and continuous audio tone. The status line of the LCD shows the type of alarm. The audio alarm may be acknowledged and silenced by pressing the **SELECT** button. If the alarm condition doesn’t clear, the audio alarm will reactivate in 5 minutes.

3.4.3 Over-range and Under-range Alarms

The over-range alarm activates audio and visual alarms. It can occur if the instrument is exposed to a gas concentration higher than its display range. Over-range alarms cannot be acknowledged. An alarm for the Toxic or Oxygen sensors clears once the over-range condition clears. The over-range alarm for the combustible sensor is latching and will not clear until the instrument has been removed from the affected area, turned off and turned on in an environment less than 100 %LEL. Under range conditions can occur if an instrument is auto-zeroed or calibrated in an area with background levels of gas. Under range alarms can be cleared by performing an auto-zero function as described in Section 3.5.1.

The over-range condition is indicated by **OVERNG** shown in the affected sensor location on the display. Under-range is indicated by **UNDRNG**.

3.4.4 Low Battery

The **TARGET** Series instrument has a low battery alarm to provide the user with adequate warning of a low battery condition. The instrument provides a steady tone audio alarm when there is approximately 15 to 30 minutes of battery life left. A low battery warning message is displayed on the status line of the instrument LCD. The audio alarm can be acknowledged by pressing the **SELECT** button. The audio alarm and backlight reactivate after approximately five minutes. See section 3.2 for battery charging procedure.

3.4.5 Fault

Fault alarms have a steady audio alarm and are displayed on the status line of the LCD. The status line describes the fault condition and appropriate action should be take to resolve the issue. See section 11 for troubleshooting information.

3.5 Pop-Up Menu

The **Pop-Up** menu is displayed after the one minute instrument warm-up procedure. The instrument beeps several times prior to showing this display. The **Pop-Up** menu provides the user the ability to perform an auto-zero, check the last date of calibration, change the combustible gas display, set user locations and activate/deactivate the optional internal pump, if installed.

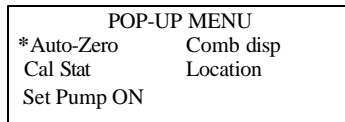

Example: Pop-Up Menu

NOTE: The *Pop-Up* menu can be accessed at any time during normal instrument operation by pressing and holding the **MENU** button for approximately two seconds while the instrument is at the *Main Gas* display.

3.5.1 Auto-Zero

To compensate for sensor aging and drift, the **TARGET** instrument has an **Auto-Zero** function. Zeroing the instrument sets all gas readings to zero and sets the oxygen to 20.9%. *This function must be performed in a fresh air environment.*

To perform an **Auto-Zero**, press and hold the Menu button to enter the **Pop-Up** menu. Note the asterisk next to **Auto-Zero**. Press the **SELECT** button. The instrument electronically compensates all sensor readings. **OK** is displayed next to all sensors where valid adjustments are made. The sensor readings must be within an acceptable range when the **Auto-Zero** function is initiated, otherwise **FAIL** or **ERR** is displayed next to the affected sensor.

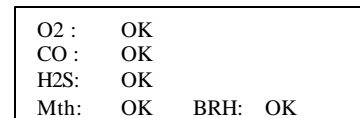
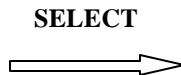
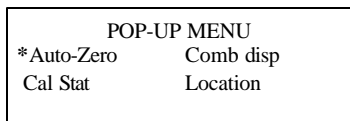

Example: Display, Auto-Zero from Pop-Up Menu

3.5.2 Calibration Status

The **TARGET** instrument keeps track of the date of last calibration for each sensor. To view the last calibration date, press and hold the Menu button to enter the **Pop-Up** menu. Press the **MENU** button two times to move the asterisk to the **Cal Status** position, then the **SELECT** button once to select the **Calibration Status** screen. The display shows the status of up to three sensors. Press the **SELECT** button to view the remaining sensors. If any of the sensors are overdue for calibration, Calibration due is displayed next to it. If a sensor has failed a calibration, Cal error is displayed next to appropriate sensor.

NOTE: OK appears next to each sensor that has been calibrated within the last 90 days. **Field tests must still be performed to confirm the performance status of each sensor.**

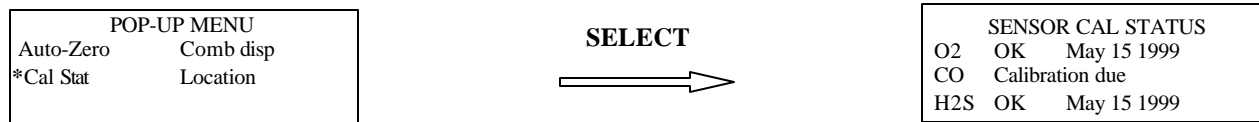

Example: Display of Calibration Status

3.5.3 Combustible Gas Display

Combustible gases vary considerably with respect to their flammable nature. Some gases are flammable at lower concentrations than others. The **TARGET** instrument has ten flammable gases response characteristics programmed in memory. Each gas has a different coefficient (K) that is used to compensate the instrument display:

Table 2: Programmed Flammable Gas Coefficients

Methane	Mth	K=1.00
Propane	Prp	K=1.88
Butane	Btn	K=2.04
Pentane	Pnt	K=2.30
Hexane	Hxn	K=2.35
Hydrogen	H2	K=1.24
Ethane	Eth	K=1.54
Benzene	Bnz	K=2.51
Toluene	Tln	K=2.47
Xylene	Xyl	K=2.99

The combustible sensor cannot determine which gas is present. When the combustible gas is unknown, it is recommended to change the display to higher K (coefficient) value gas. Hexane or Xylene may not be the gases present, but using their K value substantially increase, the instrument's sensitivity to flammable gases.

To select a different combustible gas display, press and hold the Menu button to enter the **Pop-Up** menu. Press the **MENU** button three times to move the asterisk to the **Comb disp** position. Press the **SELECT** button once to choose this screen. Press the **MENU** button to sequence through the list shown in Table 2. The instrument automatically changes the combustible display to the last one displayed.

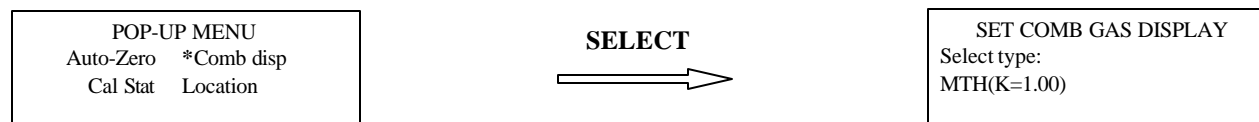

Example: Display, Combustible Gas

3.5.4 Locations

The **TARGET** instrument has the ability to store user name or locations. They are entered into the instrument using the **TARGET** Trakker software package, see section 7.0 for part number information. Set in accordance with software manual.

3.5.5 Internal Sampling Pump

If the **TARGET** instrument has the optional internal sampling pump installed, the **Pop-Up** menu provides the ability to turn the pump on and off.

To turn the pump on or off:

- Press and hold the Menu buttons to enter the **Pop-Up** menu.
- Press the **MENU** button five times to move the asterisk to the **Pump** position.
- Press the **SELECT** button once to choose this screen.
 - Press the **SELECT** button to turn the pump on
 - Press the **MENU** button to turn the pump off.

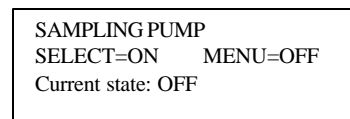
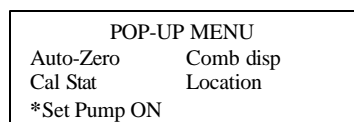

Example: Display, Internal Pump Status

If the pump is off, the bottom line of the display says “Set Pump ON”.

If the pump is on, the bottom line of the display says “Set Pump Off”.

NOTE: The Pump feature is only displayed in the Pop-Up menu if the instrument is supplied with the optional internal sampling pump.

Attach the sampling shield supplied with the instrument, to the bottom of the instrument in the same manner as the calibration shield, see Figure 8. The calibration shield has an orange label. The sampling shield has a yellow label.

Attach the supplied 20 foot sampling hose or the optional 2 foot sampling wand to the hydrophobic filter on the back of the shield.

NOTE: The sampling shield and sampling hose or wand must be firmly and correctly attached to the **TARGET** instrument for *proper remote sampling* operation.

The instrument monitors the sample pump operation and provides an audible alarm and visual indication on the status line of the display, in the event of a low flow condition.

NOTE: The sampling shield and sampling hose or wand must be removed from the **TARGET** instrument for diffusion operation.

For instruments with internal sampling pumps, a calibration procedure is required whenever a pump is replaced or when calibration is performed on the instrument sensors. It is also recommended to perform pump calibration if any abnormal pump operation is observed.

Pump calibration is performed in the Advanced Maintenance Menu. See section 6.4.8 for pump calibration instructions.

4.0 Basic User Operation

The **TARGET** instrument has two operation levels, **BASIC** and **ADVANCED**. The **BASIC** mode is intended to simplify instrument operation and discussed here. The **ADVANCED** menu provides additional information and is discussed in section 5. The instrument may be changed to the **ADVANCED** menu by following the procedure outlined in sections 6.3 and 6.3.7.

The **TARGET** operational menu is used to access various information stored in the instrument electronics. The **MENU** button is pressed to display the operational menu and an asterisk is displayed next to a function or sub-menu. Pressing the **MENU** button repeatedly, advances the asterisk once for each press. To display a sub-menu or listed function, press the **SELECT** button when the asterisk is next to desired function or sub-menu. See section 9.1 for a flow diagram of Basic Operation Menu.

4.1 Date/Time/Battery Information

From the main gas display, press the **MENU** button once to put the asterisk next to the **Date/Time/Batt** line. Press the **SELECT** button to enter the **Date/Time/Batt** line screen. The **ON:** value is the elapsed time that the instrument has been on. The battery gauge is a vertical bar graph on the bottom line of the display that provides relative information on amount of battery life left. The temperature figure in the upper right hand corner of the display is the internal enclosure temperature and is used for temperature compensation of the gas sensors. Press the **MENU** button to return to the **Operation** menu.

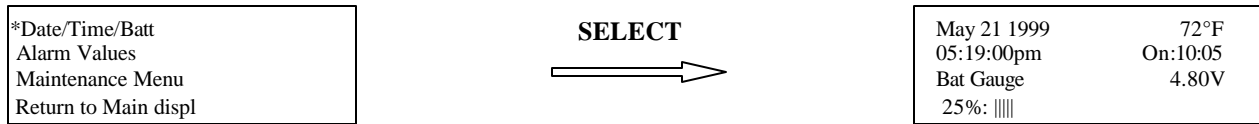

Example: Display of Date, Time, Battery Level

4.2 Alarms Values

From the main display, press the **MENU** button once to access the **Operation** menu. Press the **MENU** button again to move the asterisk next to the **Alarm values** line. Press the **SELECT** button to enter the View Alarms menu. The Low level instantaneous alarms are displayed. Press the **SELECT** button again to view the **High** level alarms. Press the **MENU** button to return to the **Operation** menu.

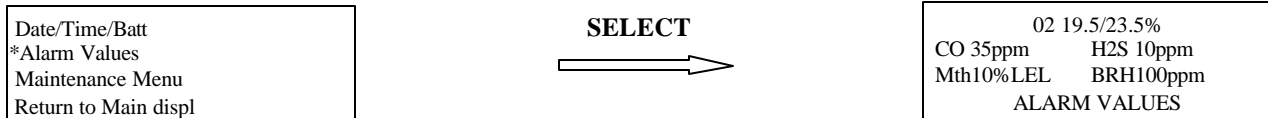

Example: Display of Alarm Values

5.0 Advanced User Operation

The **TARGET** instrument has two operation levels, **BASIC** and **ADVANCED**. The **BASIC** mode is intended to simplify instrument operation and is discussed in Section 4. The **ADVANCED** menu provides additional information and is discussed here.

The **TARGET** operational menu is used to access various information stored in the instrument electronics. Press the **MENU** button to display the operational menu and an asterisk next to a function or sub-menu. Pressing the **MENU** button repeatedly, to advance the asterisk once for each press. To display a sub-menu or listed function, press the **SELECT** button when the asterisk is next to the desired function or sub-menu. See section 9.3 for the flow diagram of the Advanced Operation Menu.

5.1 Date/Time/Battery Information

From the main gas display, press the **MENU** button once to put the asterisk next to the **Date/Time/Batt** line. Press the **SELECT** button to enter the **Date/Time/Batt** line screen. The **ON:** value is the elapsed time that the instrument has been on. The battery gauge is a vertical bar graph on the bottom line of the display that provides relative information on amount of battery life left. The temperature figure in the upper right hand corner of the display is the internal enclosure temperature and is used for temperature compensation of the gas sensors. Press the **MENU** button to return to the **Operation** menu. Same as in section 4.1.

5.2 Alarms Values

From the main display, press the **MENU** button once to access the **Operation** menu. Press the **MENU** button again to move the asterisk next to the **View Alarms** line. Press the **SELECT** button to enter the View Alarms menu. The Low level instantaneous alarms are displayed. Press the **SELECT** button again to view the **High** level alarms. Press again to view the **STEL** alarms. Press again to view **TWA** alarm points. Press the **MENU** button to return to the **Operation** menu. Same as in section 4.2.

5.3 Min/Max Values

From the main display, press the **MENU** button once to access the **Operation** menu. Press the **MENU** button two more times to move the asterisk next to the **Min / Max Values** line. Press the **SELECT** button to enter the **Min / Max Values** menu. The Min Values are displayed. Press the **SELECT** button again to view at the Max Values. Press the **MENU** button to return to the **Operation** menu.

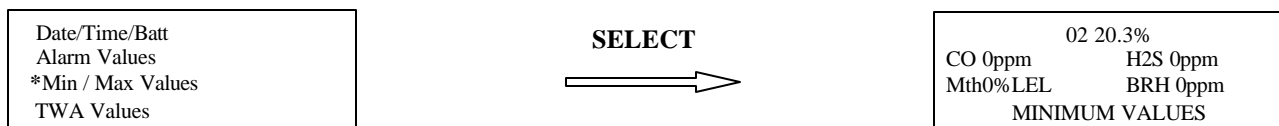

Example: Display Minimum and Maximum Values

5.4 TWA Values

From the main display, press the **MENU** button once to access the **Operation** menu. Press the **MENU** button three more times to move the asterisk next to the **TWA Values** line. Press the **SELECT** button to enter the **TWA Values** menu. The TWA current calculations are displayed. Press the **MENU** button to return to the **Operation** menu.

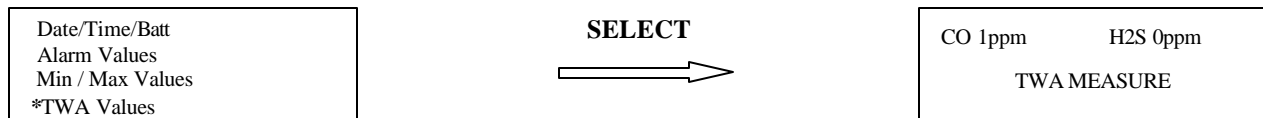

Example: Display of TWA Values

5.5 STEL Values

From the main display, press the **MENU** button once to access the **Operation** menu. Press the **MENU** button four more times to move the asterisk next to the **STEL Values** line. Press the **SELECT** button to enter the **STEL Values** menu. The STEL current calculations are displayed. Press the **MENU** button to return to the **Operation** menu.

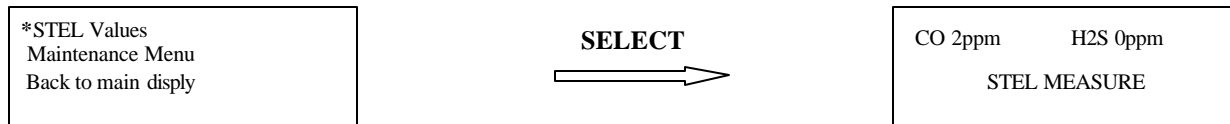

Example: Display of STEL Values

6.0 Maintenance Operations

6.1 Recommendations

Instrument calibration should be performed at least once every three months.

Field tests using gas concentrations above alarm level should be performed at least monthly or prior to each use for seldom used instruments. For frequently used instruments, field tests should be performed bimonthly to weekly. A field test consists of applying field test or calibration gas and confirming appropriate gas sensor response.

Instruments with sensors installed in the BRH location should remain on charge when not in use to stabilize sensor response.

6.2 Standard Maintenance Menu

The **Standard Maintenance** menu provides the quickest and simplest access to the most common maintenance procedure, instrument calibration.

To enter the **Standard Maintenance** menu, press the **MENU** button repeatedly from the main gas display or **Operation** menu. Move the asterisk until it is next to the **Maintenance Menu** line. Press the **SELECT** button to move to the password entry screen. *The password is set to 1270 from the factory.* Note the cursor under the first digit. Use the **MENU** button to increment the digit and the **SELECT** key to move the cursor to the next digit. Press **SELECT** when the password has been entered. If proper password is not entered, **INVALID PASSWORD** is displayed and the instrument returns to **Operation** menu.

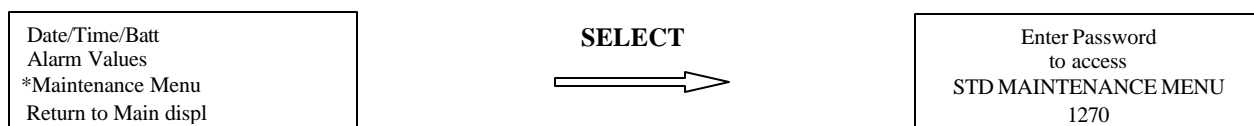

Example: Display, Password to Enter Maintenance Menu

Once in the **Standard Maintenance** menu, the options are to enter the **Calibration** menu or exit. Press the **SELECT** button to enter the Calibration Menu.

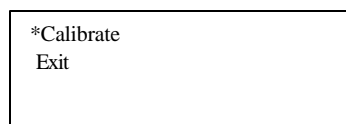

Example: Display of Maintenance Menu

6.3 Calibration

6.3.1 Calibration Menu

Calibration is the process of aligning the instrument electronics to the installed sensors, making the instrument read accurately. It consists of a zero reading which tells the instrument what it should read in fresh air, and a span reading which tells the instrument what it should read in the presence of its target gas.

Instruments configured for the combination of gases CO/H2S/O2/Mth, sensors may be calibrated all at once with multi-component gas. All other configurations, calibration must be performed for each sensor individually. See section 7.0 for **ENMET** part numbers of available calibration gas.

To initiate a calibration procedure, move the asterisk to the appropriate location using the **MENU** button. Press the **SELECT** button to choose the calibration procedure. If **N/A** appears next to a sensor then that sensor is not installed in the instrument and calibration is not possible.

NOTE: The calibration procedure may be aborted by pressing the **MENU** button anytime during the process.

NOTE: If a sensor is installed in the BRH location, the instrument display may show BRH, HS+, CO+, Tol, or similar. It will always appear above the O2/CO/H2S/Mth combination calibration. The instrument must be on charge over night prior to calibration or field test.

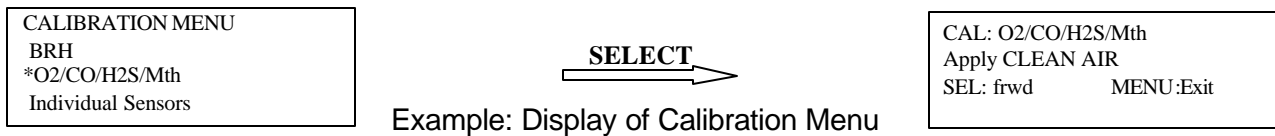

6.3.2 Zero Adjust

The calibration **zero** procedure is activated by pressing the **SELECT** button again. This starts a 30 second count down timer, at the end of which, the zero reading is stored in memory. The next screen displays the span gas concentration.

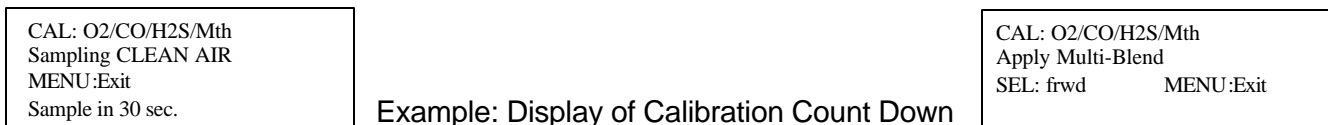

NOTE: The oxygen sensor requires only the initial 30 second clean air procedure.

6.3.3 Applying Span Gas

Attach the calibration adapter to the cylinder of span gas and calibration shield. See figure 8.

IF A SENSOR IS INSTALLED IN BRH LOCATION:

- Place instrument on charge over night.
- **The BRH sensor should be calibrated before any others.** If the BRH sensor is installed in the **TARGET**, it will become contaminated if exposed to the combination or test gas and must be calibrated separately.
- If the BRH sensor is being calibrated, fill the humidifier bowl approximately 1/3 full with clean, tap water. The tube should **NOT** go under the water line. No bubbles should be visible when gas is flowing. See figure 8.

NOTE: The arrow on the humidifier bowl points in the opposite direction of airflow.

- **Failure to follow both of the BRH steps will cause an inaccurate calibration.**

FOR ALL OTHER SENSORS INSTALLED:

- Use the reactive gases calibration adapter which does not have a humidifier bowl. For CO, O2, Methane sensor calibration these sensors may be calibrated simultaneously or individually using the combination calibration gas and reactive gases calibration adapter. See figure 8.

NOTE: When calibrating CO, O2 and CH4, with individual gas cylinders, the BRH calibration adapter should be used.

- **Failure to do so will cause an inaccurate calibration.**

SPAN gas concentrations are not adjustable in this calibration procedure. SPAN gas concentrations are, by design, the concentrations available with ENMET calibration kits. See Section 8.0 for the default concentrations. If other concentrations are to be used for calibration, the calibration procedure in the Advanced Maintenance menu must be followed.

NOTE: If the span gas value has been previously changed in the Advanced Maintenance menu, that change is carried over to this procedure.

Attach the calibration shield to the sensor end cap of the instrument. See Figure 8. Guide the flap of the shield into the groove on the bottom of the end cap and bring the top of the shield towards the top of the end cap. Tighten the thumb screw into the threaded hole in the sensor end cap.

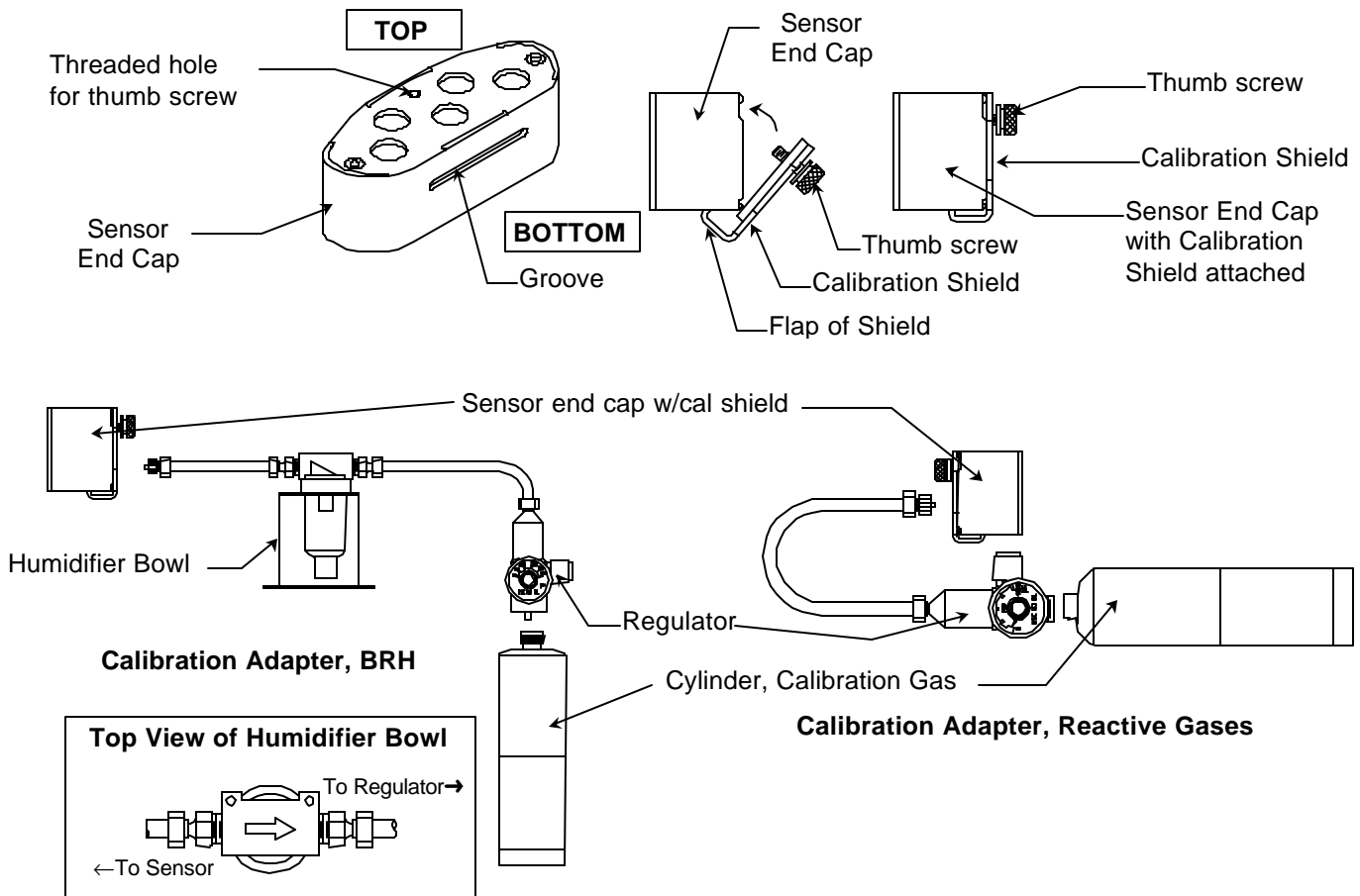

Figure 8: Calibration Adapter Attachment

Apply the span gas and press the **SELECT** button to initiate the sample count down timer. Count down is shown on the lowest line of the display, at the end of the count down the span reading is stored in memory. Remove the span gas and the calibration shield. Calibration of this sensor is complete.

If the sensor is within acceptable sensitivity parameters, OK is displayed next to the gas momentarily before the display returns to the **Calibration** menu.

If there is a problem, **Cal error** is displayed next to the appropriate channel. See section 10.0 for troubleshooting.

CAL: O2/CO/H2S/Mth Sampling MULTI-BLEND MENU:Abort Sample in 120 sec.	O2: OK CO: Cal error H2S: OK Mth: OK
--	---

Example: Display during and after Calibration

Repeat the above procedure for each individual sensor as required. If a calibration error occurs it will also be displayed as a general condition on the **Status Line** of the **Main Gas Display** and can be viewed in the **Cal Status** screen of the **Pop-Up menu**.

Exit the **Calibration** menu when completed. Remove span gas and calibration shield. Then exit the **Standard Maintenance** menu.

6.4 Advanced Maintenance Menu

The **Advanced Maintenance** menu provides access to enhanced programming features of the **TARGET** instrument.

To enter the **Advanced Maintenance** menu, press the **MENU** button repeatedly from the main gas display or Operation menu. Move the asterisk until it is next to the **Maintenance** menu line. Press the **SELECT** button to move to the password entry screen. *The password is set to 1270 from the factory.* Press and hold the **MENU** button for about two seconds. Note that the third line changes from **STD Maintenance Menu** to **ADV Maintenance Menu**. Use the **MENU** button to increment the first digit and the **SELECT** button to move the cursor to the next digit. Press **SELECT** when the proper password has been entered. If proper password is not entered, **INVALID PASSWORD** is displayed and the instrument returns to **Operation** menu.

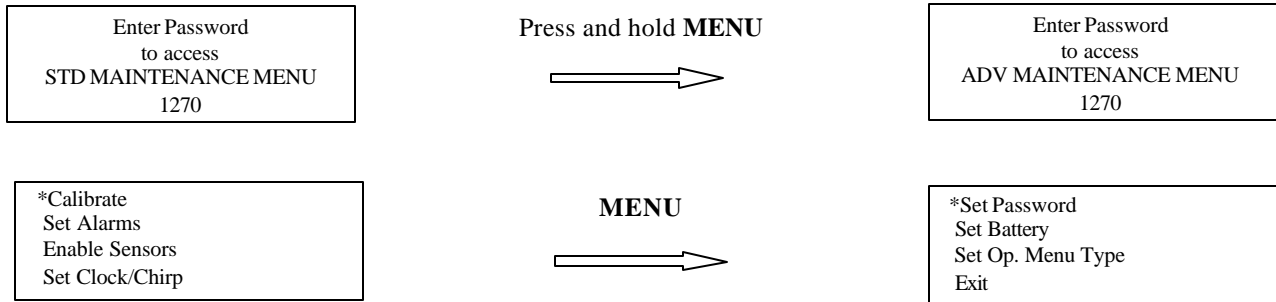

Example: Display of Advanced Maintenance Menu

6.4.1 Calibration

The calibration procedure in the **Advanced Maintenance** menu is very similar to the procedure in the **Standard Maintenance** menu, section 6.3. The difference is that in the **Advanced Maintenance** menu version, the span values can be modified and the **zero and span settings must be acknowledged by pressing the SELECT button**.

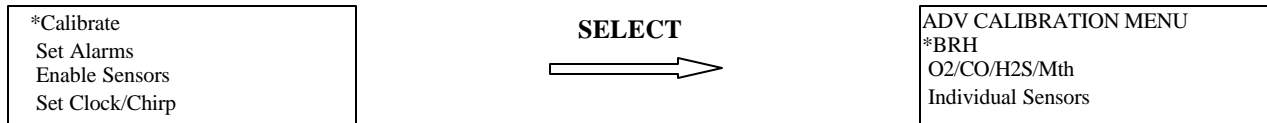

Example: Display of Advanced Calibration Menu

If the BRH sensor is installed, see section 6.3.3 for applying span gas.

Expose the instrument to fresh air. When the mV reading on the bottom line is stable, press the **SELECT** button to set the **ZERO** reading.

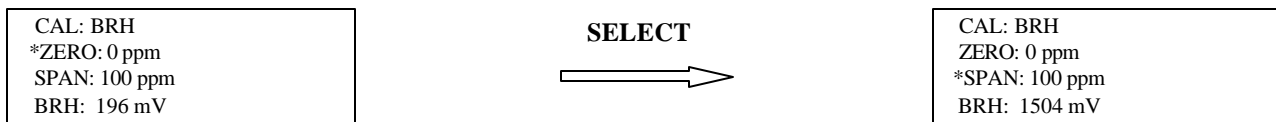

Example: Display of BRH Calibration

The asterisk now highlights the **SPAN** gas concentration. Default values for each sensor are listed in Section 8.0.

To modify the span value, use the **Menu** key to initiate the change and then increment the digits. The **SELECT** button is used to select the digit. **SELECT** the last digit only after span gas has been applied and the mV reading is stable.

If no modification is necessary, apply calibration gas and press the **SELECT** button when the mV reading is stable. Repeat the procedure for each sensor as necessary.

6.4.2 Setting Instantaneous Alarms

From the Advanced Maintenance menu, press the **MENU** button once to put the asterisk next to the **Set Alarms** line. Press the **SELECT** button to enter the **Set Alarms** screen. Use the **MENU** button to move the asterisk next to the desired gas for alarm to be changed. Press the **SELECT** button to move the cursor to the first digit. The **MENU** button is used to increment the digit and the **SELECT** button to move the cursor to the next digit. Press the **SELECT** button at the **Exit** line to go back to the **Maintenance** menu. STEL and TWA alarms are preset at the factory and can only be changed using the **TARGET**Trakker software package.

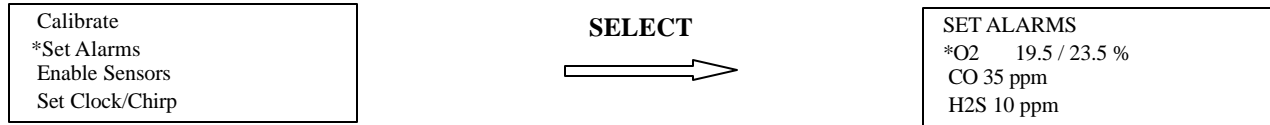

Example: Display of Set Alarm Menu

6.4.3 Enable Sensors

From the Advanced Maintenance menu, press the **MENU** button twice once to put the asterisk next to the **Enable Sensors** line. Press the **SELECT** button to enter the **Enable Sensors** screen. Use the **MENU** button to move the asterisk next to the gas whose alarm needs to be changed. Press the **SELECT** button to toggle the sensor ON or OFF. Press **SELECT** at the **Exit** line to go back to the **Maintenance** menu.

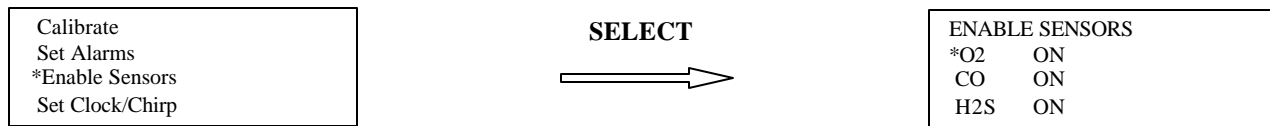

6.4.4 Set Clock/Chirp

From the Advanced Maintenance menu, press the **MENU** button three times to put the asterisk next to the **Set Clock/Chirp** line. Press the **SELECT** button to enter the **Set Clock/Chirp** screen. Use the **MENU** button to move the asterisk next to the value that needs to be changed. Press the **SELECT** button to move a cursor to the first digit. The **MENU** button is used to increment the digit and the **SELECT** button to move to the next digit.

Time must be entered in a 24 hour format (i.e. 4:30 pm is entered as 16:30). The confidence chirp sounds at interval entered in this screen. Factory default value is 120 seconds.

Press the **SELECT** button at the **Exit** line to go back to the **Maintenance** menu.

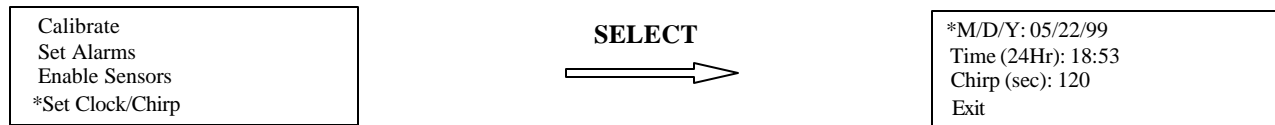

Example: Display while Setting Clock and Chirp interval

6.4.5 Set Password

From the Advanced Maintenance menu, press the **MENU** button four times to put the asterisk next to the **Set Password** line. Press the **SELECT** button to enter the **Set Password** screen. Use the **MENU** button to increment the digit and the **SELECT** button to move to the next digit. Any four digit password from 0000 to 9999 may be entered by this operation.

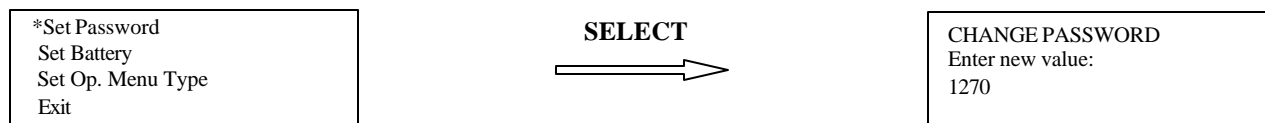

Example: Display Changing Password

6.4.6 Set Battery Type

From the Advanced Maintenance menu, press the **MENU** button five times to put the asterisk next to the **Set Battery** line. Press the **SELECT** button to enter the **Set Battery** screen. Use the **MENU** button alternate between **NiMH** (rechargeable) and **Alkaline**. Press the **SELECT** button to choose the desired battery type. Setting the proper battery type is important to achieve maximum life out of the battery pack.

WARNING: Substitution of batteries or other components may compromise the intrinsic safety of the instrument.

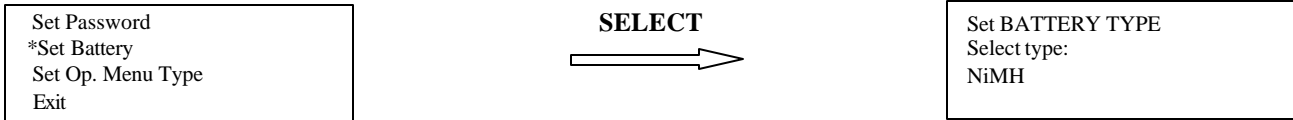

Example: Display Setting Battery Type

6.4.7 Set Operation Menu

From the Advanced Maintenance menu, press the **MENU** button six times to put the asterisk next to the **Set Op. menu type** line. Press the **SELECT** button to enter the **Set Op. menu type** screen. Use the **MENU** button alternate between **Basic** and **Advanced**. Press the **SELECT** button to choose the desired operational menu. The **Basic** menu type is the default menu.

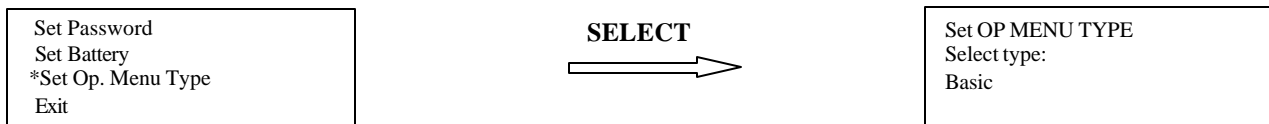

Example: Display of Set Operation Menu

6.4.8 Internal Pump Calibration

For instruments with internal sampling pumps, a calibration procedure is required whenever a pump is replaced or when calibration is performed on the instrument sensors. It is also recommended to perform pump calibration if any abnormal pump operation is observed.

NOTE: The calibration or sampling shield should *not* be attached to the instrument during pump calibration.

- Press the menu button to move the asterisk next to the Pump Calibration prompt.
- Press the select button to initiate the procedure.
- The pump will automatically come on. The instrument samples the pump signal for one minute. At the end of the one minute, the instrument is ready for the blocked flow measurement.
- Put your finger over one of the two sampling holes on the back of the sensor housing.
- Press the select button. The instrument samples the blocked flow condition for 10 seconds and then stores the reading. See figure 9, for location of sampling holes.

The low flow alarm is set automatically by the instrument based on the free flow and blocked flow readings. No further adjustments are necessary.

Exit the Maintenance Menu when maintenance operations are complete.

6.5 Replacing Battery Pack

WARNING: Substitution of batteries or other components may compromise the intrinsic safety of the instrument.

Replacing the battery pack is accomplished by removing the two screws holding the sensor end-cap of the instrument housing. A 2 mm allen key is required. Slide the battery pack out and disconnect it from the PCB connector.

CAUTION: the battery pack cable has a locking connector. The center tab must be pushed down before the connector can be removed.

Connect the new battery pack to the PCB and slide the battery pack into the instrument housing. See figure 9.

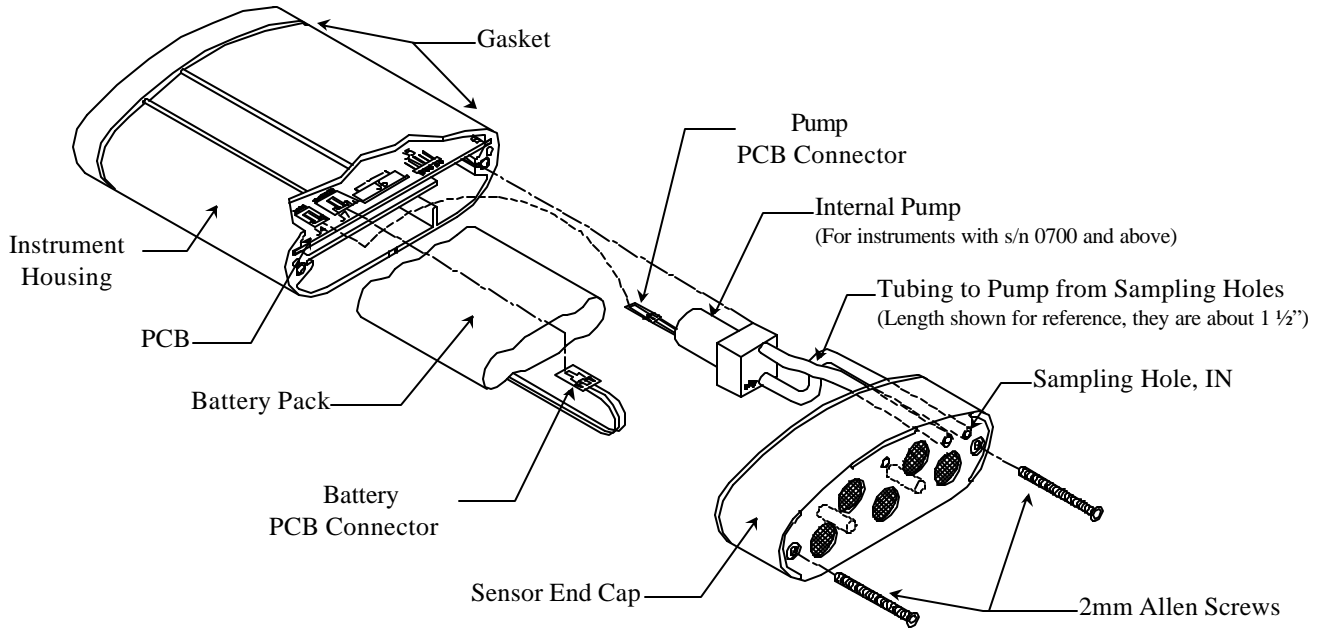

Figure 9: Replacing Battery Pack and Internal Pump

CAUTION: Be sure to properly install the gasket when re-assembling the instrument. The best technique is to thread the screws most of the way in. Install the gasket, then tighten the screws.

CAUTION: Be sure that all wires and tubing will not be pinched or stressed when sensor end cap is replaced.

6.6 Replacing Internal Pump

Replacing the internal pump is accomplished by removing the two screws holding the sensor end-cap of the instrument housing. A 2 mm allen key is required. Slide the internal pump out and disconnect it from the PCB connector and the tubing from the pump.

CAUTION: the internal pump cable has a locking connector. The center tab must be pushed down before the connector can be removed.

CAUTION: Be sure that all wires and tubing will not be pinched or stressed when sensor end cap is replaced.

For instruments with s/n 0700 and *above*:

Connect the new pump to the PCB and tubing. Pump IN port is indicated by arrow. See figure 9.

For instruments with s/n 0699 and *below*:

Connect the new pump to the PCB and tubing.

Pump IN port is indicated on the pump.

Attach pump to bracket. See figure 9a.

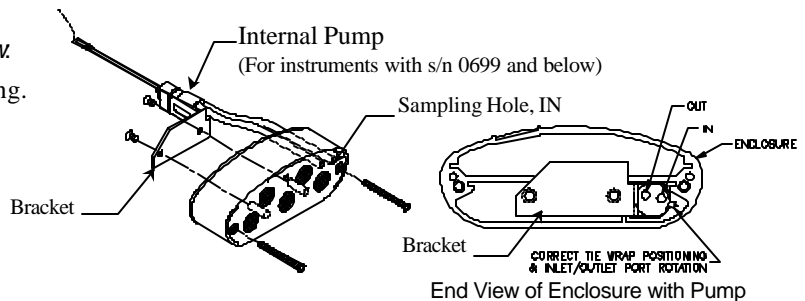

Figure 9a: Replacing Internal Pump for instruments with s/n 0699 and below

6.7 Replacing Sensors

When sensors can no longer be calibrated, they must be replaced. Replacing them is accomplished by removing the two screws holding the sensor end-cap of the instrument housing. A 2 mm allen key is required. Two #6-32 screws hold a bracket over the sensor board. Remove the screws and bracket. Remove the 2 spacers beneath the bracket to remove the sensor circuit board. Replace sensors as necessary and re-assemble. See figures 10 and 11.

CAUTION: New TOX1 and TOX2 sensors come with a shorting clip that must be removed for proper operation.

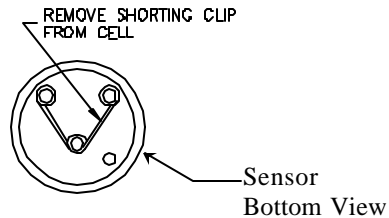

Figure 10: Remove shorting clip

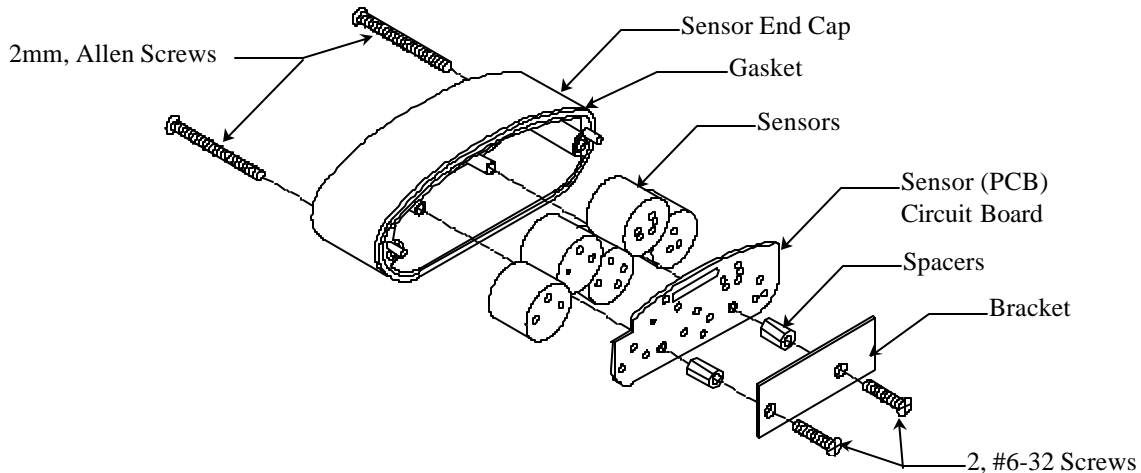

Figure 11: Replacing Sensors

NOTE: Be sure to properly install the gasket when re-assembling the instrument. The best technique is to thread the screws most of the way in. Install the gasket, then tighten the screws.

CAUTION: Be sure that all wires and tubing will not be pinched or stressed when sensor end cap is replaced.

If your **TARGET** instrument was ordered with less than five sensors installed, one or more sensor inserts have been installed. These inserts are not operational and are installed to provide environmental and structure integrity of the sensor housing. If activating any of these is desired, contact **ENMET** or your local distributor for upgrade information.

7.0 Instrument Information

7.1 Replacement Parts List

ENMET Part No.	Description
04835-000	Sampling hose
04835-001	Sampling wand
04835-002	Hand aspirator, requires 04835-000 or 04835-001 or both
04833-000	Protective carrying case
04833-003	Alkaline battery holder
66014-003	Charger cable, 12 Vdc
73083-007	Economy Black Transit Case with Lining
04832-000	Battery Charger, 100-240 VAC, req. cable 66018-000 or equiv.
66018-000	Power cable for charger, 110 VAC plug
67019-024	Battery Pack, NiMH
04805-006	Internal Pump, <i>for units with s/n 0699 and below</i>
04805-008	Internal Pump, <i>for units with s/n 0700 and above</i>
03620-017	Calibration/hand aspirator cover
04833-001	Computer Cable
04836-000	Sampling cover for internal sample pump
73089-068	Sampling filter
03008-131	Sensor, BRH
03015-012	Sensor, HS+/CO+
03070-002	Sensor, Combustible (HW)
67016-1104	Sensor, Oxygen
67025-0100	Sensor, Chlorine
67025-0200	Sensor, Hydrogen sulfide
67025-0300	Sensor, Hydrogen cyanide
67025-0400	Sensor, Hydrogen chloride
67025-0500	Sensor, Sulfur dioxide
67025-0800	Sensor, Ozone
67025-1200	Sensor, Carbon monoxide
67025-1700	Sensor, Nitrogen dioxide
67025-1750	Sensor, Nitric oxide
67025-2400	Sensor, Ammonia
80012-014	TARGET Series Operation and Maintenance Manual
03388-000	Calibration Gas, 34 liter, 50% LEL CH ₄ , 20ppm H ₂ S, 100 ppm CO, 20.9% O ₂
03286-100	Calibration Gas, 17 liter, 100ppm Toluene for BRH Sensor
03220-050	Calibration Gas, 17 liter, 50% LEL Methane, CH ₄
03219-100	Calibration Gas, 17 liter, 100ppm Carbon Monoxide, CO
03302-010	Calibration Gas, 34 liter, 10ppm Hydrogen chloride, HCL
03303-010	Calibration Gas, 34 liter, 10ppm Hydrogen cyanide, HCN
03314-020	Calibration Gas, 34 liter, 20ppm Hydrogen Sulfide, H ₂ S
03315-010	Calibration Gas, 17 liter, 10ppm Sulfur Dioxide
03318-025	Calibration Gas, 17 liter, 25ppm Ammonia
03331-005	Calibration Gas, 17 liter, 5ppm Chlorine
03334-025	Calibration Gas, 34 liter, 25ppm Nitric oxide
04834-001	Calibration Adapter, Reactive Gases
04834-002	Calibration Adapter, for BRH sensor
03620-017	Calibration Shield
Contact ENMET	Trakker software

7.2 Target Specifications

Element	Specification
Dimensions	6 x 4.5 x 1.7 inches (150 x 115 x 45 mm)
Weight	32 ounces (900 grams)
Operating Temperature	5 F° to 122 F° (-15 C° to 50 C°)
Storage Temperature	122 F° to 140 F° (-30 C° to 60 C°)
Operating Humidity	5 – 99% (non-condensing)
Enclosure Material	Aluminum Extrusion and Castings
Approval Rating	Approved instruments are identified by the presence of the CSA logo on the instrument serial number label. CSA approval for Intrinsic Safety, Class 1, Div 1, Groups A,B,C,D
Power Source	Battery Pack: Nickel-Metal Hydride

NOTE: *Any specifications stated in this manual may change without notice.*

8.0 Default Alarm and Configurations

Table 3: Default Alarm

Gas	Full Scale Display	Resolution	Alarm 1	Alarm 2	TWA	STEL	Calibration Gas Value
Ammonia	99 ppm	1 ppm	25 ppm	50 ppm	25 ppm	35 ppm	25 ppm NH ₃
Arsine	1.00 ppm	0.01 ppm	0.05 ppm	0.10 ppm	0.10 ppm	0.10 ppm	0.5 ppm PH ₃ 0.5 ppm /AsH ₃
BRH	200 ppm	1 ppm	100 ppm	150 ppm	X	X	100 ppm C ₇ H ₈ (toluene)
Carbon Monoxide	500 ppm	1 ppm	35 ppm	200 ppm	35 ppm	200 ppm	100 ppm CO
Chlorine	9.9 ppm	0.1 ppm	0.5 ppm	5.0 ppm	.05 ppm	1.0 ppm	5 ppm Cl ₂
Chlorine Dioxide	3.00 ppm	0.01 ppm	0.10 ppm	0.30 ppm	0.10 ppm	0.30 ppm	1.0 ppm Cl ₂
CO+ (BRH)	100 ppm	1 ppm	35 ppm	75 ppm	X	X	35 ppm CO
Combustible	99 %LEL	1 %LEL	10 %LEL	50 %LEL	X	X	50 %LEL CH ₄
HS+ (BRH)	40 ppm	1 ppm	10 ppm	20 ppm	X	X	20 ppm H ₂ S= 50 ppm CO
Hydrogen Chloride	20.0 ppm	0.1 ppm	5.0 ppm	10.0 ppm	5.0 ppm	5.0 ppm	10 ppm HCl
Hydrogen Cyanide	20.0 ppm	0.1 ppm	4.7 ppm	10.0 ppm	4.7 ppm	4.7 ppm	10 ppm HCN
Hydrogen Floride	10.0 ppm	0.1 ppm	0.3 ppm	6.0 ppm	3.0 ppm	3.0 ppm	5.0 ppm HF
Hydrogen Sulfide	200 ppm	1 ppm	10 ppm	20 ppm	10 ppm	15 ppm	20 ppm H ₂ S
Ozone	3.00 ppm	0.01 ppm	0.10 ppm	0.30 ppm	0.10 ppm	0.10 ppm	0.3 ppm O ₃
Oxygen	30 % volume	0.1 % volume	19.5%	23.5%	X	X	20.9 % O ₂
Phosphine	2.00 ppm	0.01 ppm	0.30 ppm	1.50 ppm	0.30 ppm	1.5 ppm	0.5 ppm PH ₃
Nitrogen Dioxide	30.0 ppm	0.1 ppm	1.0 ppm	5.0 ppm	1.0 ppm	1.0 ppm	5 ppm NO ₂
Sulfur Dioxide	30.0 ppm	0.1 ppm	2.0 ppm	10.0 ppm	2.0 ppm	5.0 ppm	5 ppm SO ₂

X = not applicable.

Table 4: Default Configuration

Operation Menu:	Basic
Confidence chirp interval:	120 seconds
Backlight duration:	30 seconds
Combustible gas display:	Methane
Datalogging:	Active (requires TARGET Trakker to retrieve)
Datalogging interval:	1 per minute
TWA/STEL Alarms:	Active
Locations:	Enabled (requires TARGET Trakker to set)

9.0 Flow Diagrams

Table 5: Target Menu Quick Reference

Basic Operation: See section 9.1	Main Gas Display; Date/Time/Battery; Alarm Values; Maintenance Menu; Back to Main Display
Advanced Operation: See section 9.3	Main Gas Display; Date/Time/Battery; Alarm Values; Min/Max; TWA Values; STEL Values; Maintenance Menu; Back to Main Display
Standard Maintenance: See section 9.2	Calibration; EXIT
Advanced Maintenance: See section 9.4	Calibration; Set Alarms; Enable Sensors; Set Clock/Chirp; Set Password; Set Battery; Set Operation Menu Type; EXIT

9.1 Basic Operation Menu

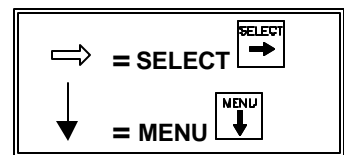
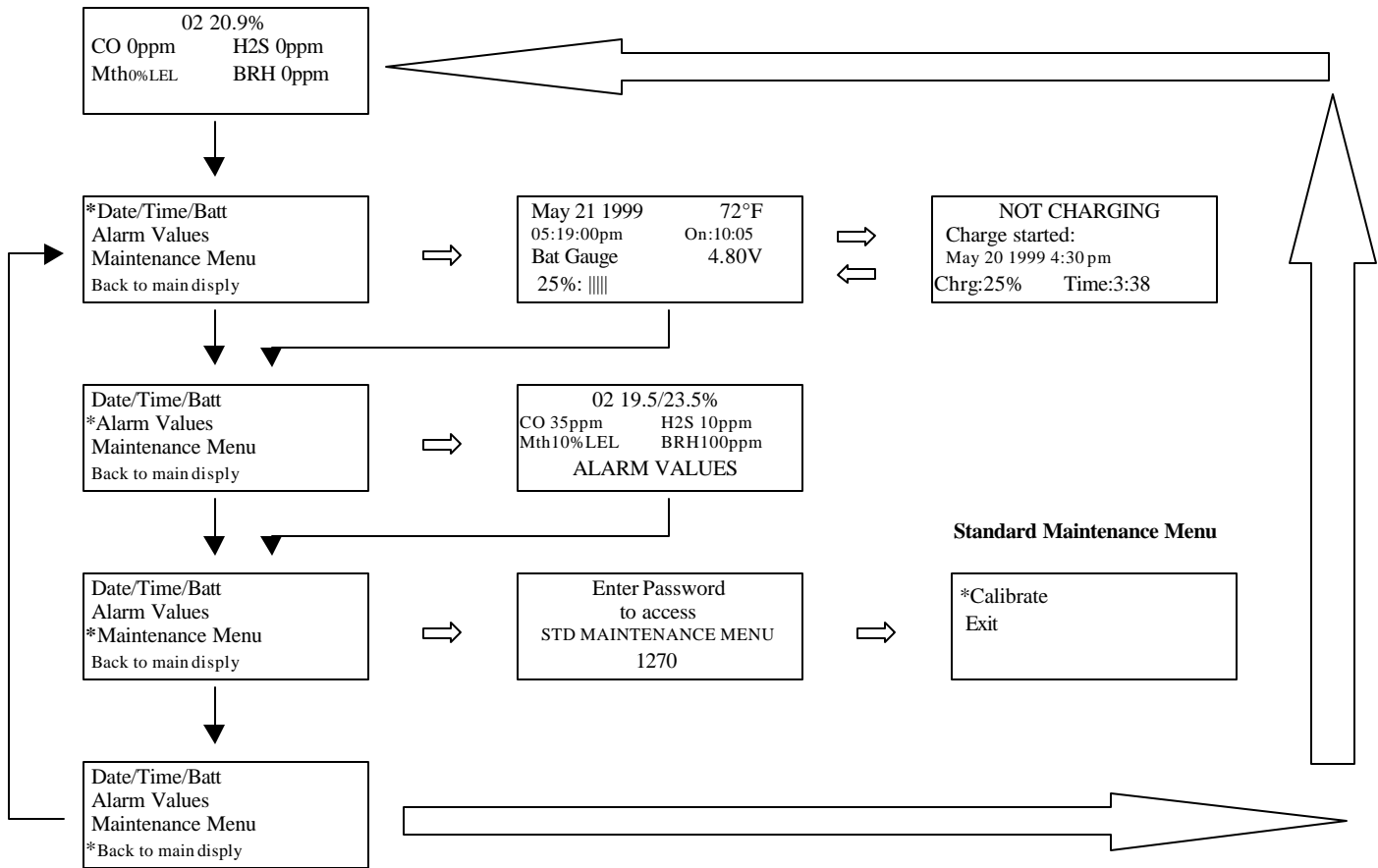

9.2 Standard Maintenance Menu

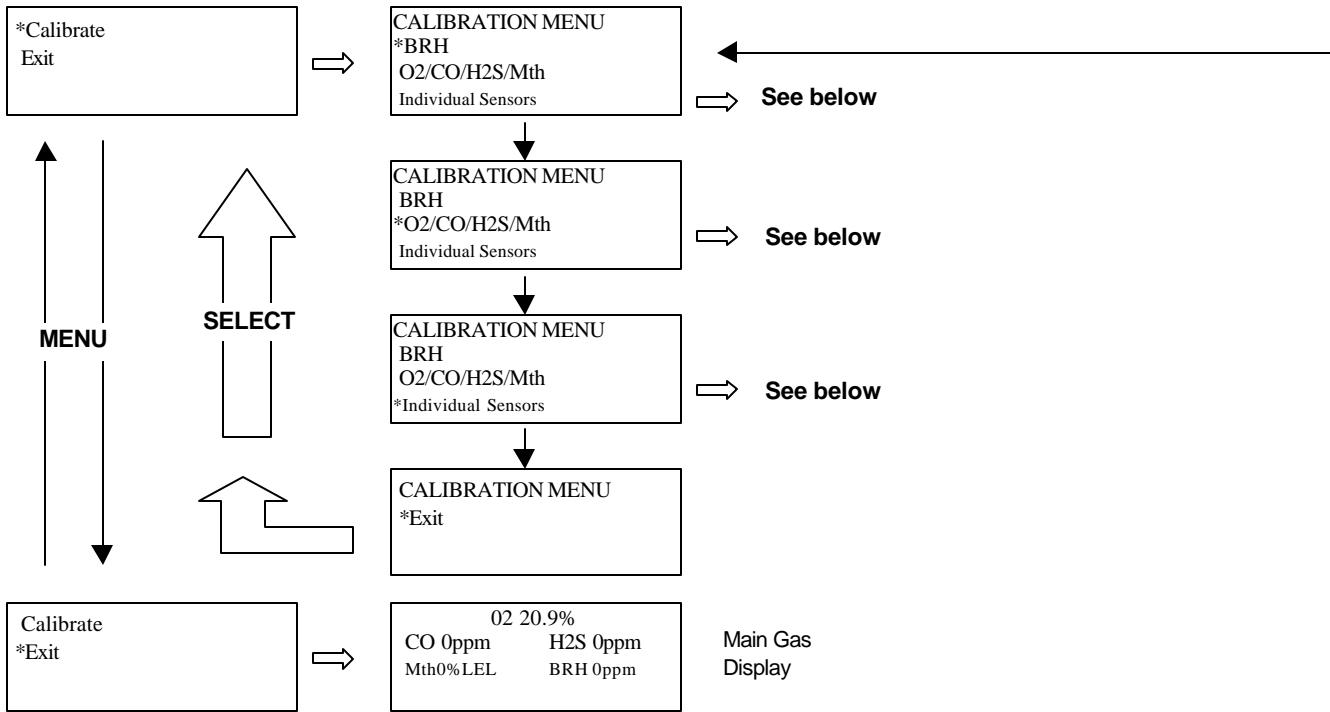

Enter any calibration procedure from above:

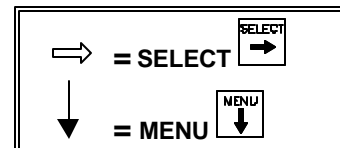
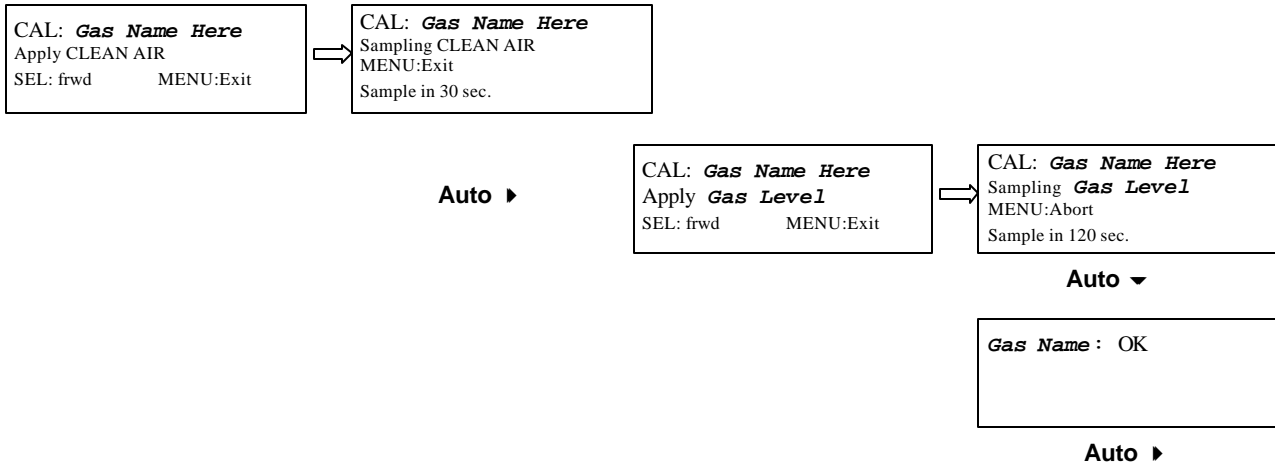

9.3 Advanced Operation Menu

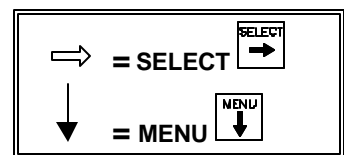
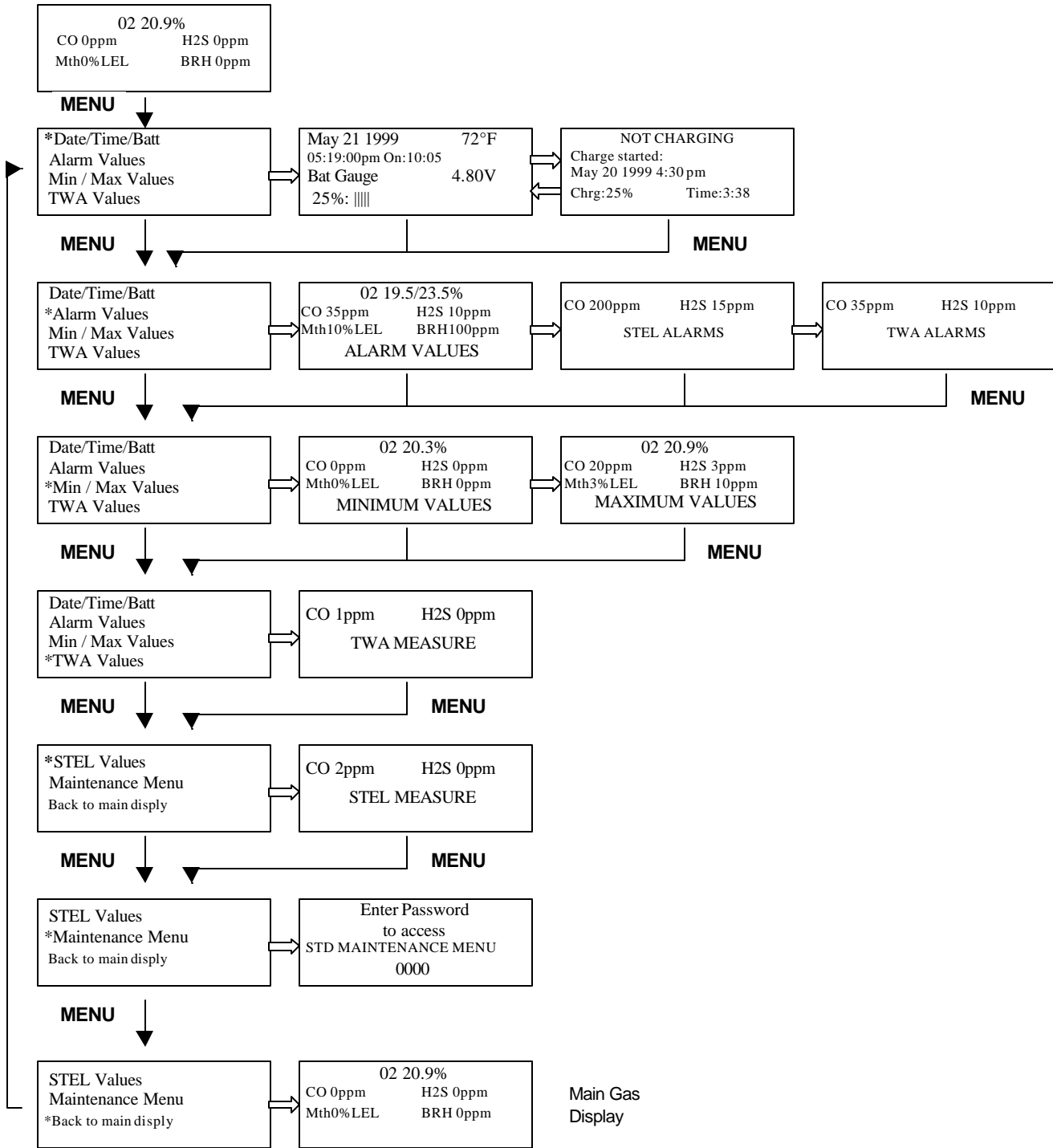

9.4 Advanced Maintenance Menu

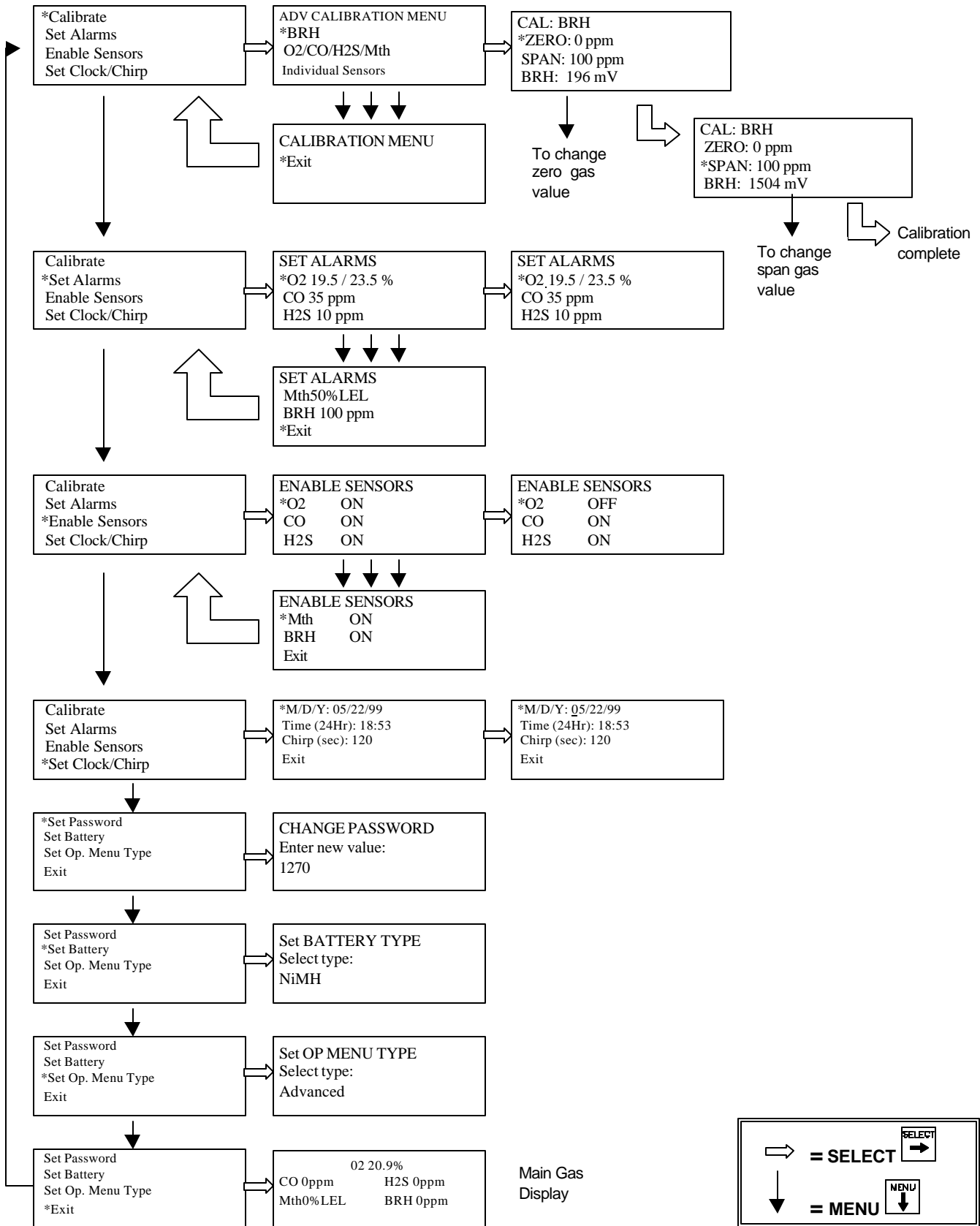

10.0 Troubleshooting

Symptom	Possible Cause	Action
Unit will not turn on.	Dead battery	Plug instrument into charger. Check charge status.
Sensor fails calibration	Failed sensor Wrong gas concentration Old calibration gas	Replace sensor and recalibrate Use proper calibration gas. Replace calibration gas.
Calibration due on status line	Sensor hasn't been calibrated in last 30 days.	Check Cal Status in Pop-Up menu. Calibrate affected sensor(s).
Cal error on status line	Sensor failed a calibration.	Check Cal Status in Pop-Up menu. Calibrate affected sensor(s). Replace sensor if necessary and recalibrate.
Setup/config error on status line	Memory failure Battery back-up failure.	Return to factory/service center. Return to factory/service center.
Fault displayed in sensor location	Sensor missing. Invalid sensor readings.	Properly install sensor. Check sensor calibration. Replace if necessary.

11.0 WARRANTY

ENMET warrants new instruments to be free from defects in workmanship and material under normal use for a period of eighteen months from date of shipment from **ENMET**. The warranty covers both parts and labor excluding instrument calibration and expendable parts such as calibration gas, filters, batteries, etc... Equipment believed to be defective should be returned to **ENMET** within the warranty period (transportation prepaid) for inspection. If the evaluation by **ENMET** confirms that the product is defective, it will be repaired or replaced at no charge, within the stated limitations, and returned prepaid to any location in the United States by the most economical means, e.g. Surface UPS/RPS. If an expedient means of transportation is requested during the warranty period, the customer is responsible for the difference between the most economical means and the expedient mode. **ENMET** shall not be liable for any loss or damage caused by the improper use of the product. The purchaser indemnifies and saves harmless the company with respect to any loss or damages that may arise through the use by the purchaser or others of this equipment.

This warranty is expressly given in lieu of all other warranties, either expressed or implied, including that of merchantability, and all other obligations or liabilities of **ENMET** which may arise in connection with this equipment. **ENMET** neither assumes nor authorizes any representative or other person to assume for it any obligation or liability other than that which is set forth herein.



PO Box 979
680 Fairfield Court
Ann Arbor, Michigan 48106-0979
734.761.1270 Fax 734.761.3220

Returning an Instrument for Repair

ENMET instruments may be returned to the factory or any one of our Field Service Centers for regular repair service or calibration. The **ENMET** Repair Department and Field Service Centers also perform warranty service work.

When returning an instrument to the factory or service center for service, paperwork must be included which contains the following information:

- A purchase order number or reference number.
- A contact name with return address, telephone and fax numbers
- Specific instructions regarding desired service or description of the problems being encountered.
- Date of original purchase and copy of packing slip or invoice for warranty consideration.
- If a price estimate required, please note it accordingly **and be sure to include a fax number.**

Providing the above information assists in the expedient repair and return of your unit. **Failure to provide this information can result in processing delays.**

ENMET charges a one hour minimum billing for all approved repairs with additional time billed to the closest tenth of an hour. All instruments sent to **ENMET** are subject to a minimum \$30 evaluation fee, even if returned unrepared. Unclaimed instruments that **ENMET** has received without appropriate paperwork or attempts to advise repair costs that have been unanswered, after a period of 60 days, may be disposed of or returned unrepared COD with the \$30 evaluation fee.

Service centers may have different rates or terms. Be sure to contact them for this information.

Repaired instruments are returned by UPS/RPS surface and are not insured unless otherwise specified. If expedited shipping methods or insurance is required, it must be stated in your paperwork.

Note: Warranty of customer installed components.

If a component is purchased and installed in the field, and fails within the warranty term, it can be returned to **ENMET** and will be replaced, free of charge, per **ENMET**'s returned goods procedure.

If the entire instrument is returned to **ENMET** Corporation with the defective item installed, the item will be replaced at no cost, but the instrument will be subject to labor charges at a rate of half of the standard rate.



Repair Return Form

Mailing Address:
ENMET Corporation
PO Box 979
Ann Arbor, Michigan 48106

Shipping Address:
ENMET Corporation
Attn: Repair Department
680 Fairfield Court
Ann Arbor, Michigan 48108

Phone Number: 734.761.1270

FAX Number: 734.761.3220

Your Mailing Address:

Your Shipping Address:

Contact Name: _____

Your Phone: _____

Your Reference Number: _____

Your FAX: _____

Payment Terms: COD
(check one)

VISA / MasterCard _____
Card number

Expiration

Return Shipping Method:

UPS/RPS Surface: 3 day 2nd Day Air Next Day Air

Federal Express: Next Day Morning Next Day Afternoon Standard

FedEx Account number: _____

Would you like ENMET to insure the return shipment?

No Yes Insurance Amount: \$ _____